

Basyx VAV / VVR

Variable Air Volume Controller

Installation Manual

VAV/VVR-IM Revision 3.2
06/14/2007

BASYX VAV/VVR

Variable Air Volume Controller

Table of Contents

Before Installing	3
VAV Board Layout	4
Mounting the Unit	5
New Construction	5
Retrofit	7
Connecting the Power	10
Communications Bus Wiring	11
Setting The Device Address	13
Connecting Temperature Sensors	14
Room Sensor	15
Duct Sensor	16
Connecting Digital Inputs	16
Connecting Digital Outputs	17
Pilot Relays	17
Fan Powered Box Outputs	18
Connecting Analog Output	19
Connecting the Velocity Sensor	20
Operation	21
Basic Troubleshooting	21
Specifications	22
About the BASYX Product Line	23
Appendix 1: BASYX Address Switch Settings	24
Appendix 2: Manufacturer Box Constants	26
Appendix 3: Recommended Cable	32

Warning (For your Safety)

All electrical connections must be in agreement with local codes ordinances, or the National Electric Code (NEC).

Do not install in areas that experience high levels of electrical interference, moisture or exposure to water.

BEFORE INSTALLING

Check contents for any sign of damage. If the VAV assembly is damaged in any way, contact the dealer or seller immediately.

The BASYX VAV comes ready to mount directly onto the damper shaft using the attached V-Clamp. The VAV electronics board is housed within the clamshell type enclosure and the entire assembly is attached to the duct with one sheet metal screw.

If using the BASYX VVR board with a motor other than a BELIMO, contact your TMS dealer to verify compatibility and power requirements.



Figure 1: BASYX VAV controller assembly



Figure 2: BASYX VVR retrofit controller

The VAV controller assembly is designed for use on new construction projects or retrofit of existing variable air volume terminals where actuators are replaced, i.e. pneumatic conversion, etc. The controller is a self-contained unit which consists of a plastic enclosure and 3-wire floating damper actuator.

The VVR retrofit controller is used on existing variable air volume terminals where existing 3-wire floating actuators may be reused. The unit is a snap-track mounted unit, and may be installed in existing VAV unit control enclosures.

Figure 1 shows the VAV controller assembly and **Figure 2** shows the VVR retrofit controller.

Contact Triangle MicroSystems or your local dealer/distributor if unsure about the compatibility of any existing actuator or box type.

MOUNTING THE UNIT

VAV NEW CONSTRUCTION INSTALLATION

The VAV must be mounted in a relatively clean environment, free from major airborne dust and contaminants (moisture, oil, etc.). Keep the VAV away from high voltage equipment that might disrupt communications and away from high vibration equipment. Do not mount the unit near any sources of electromagnetic interference (EMI) or flammable vapors.

Install the VAV controller on the VAV terminal by placing the opening of the actuator over the damper shaft extended from the box as shown in **Figure 4**. Make sure that the terminal end of the enclosure is over a flat area of the box, or a mounting bracket must be used.

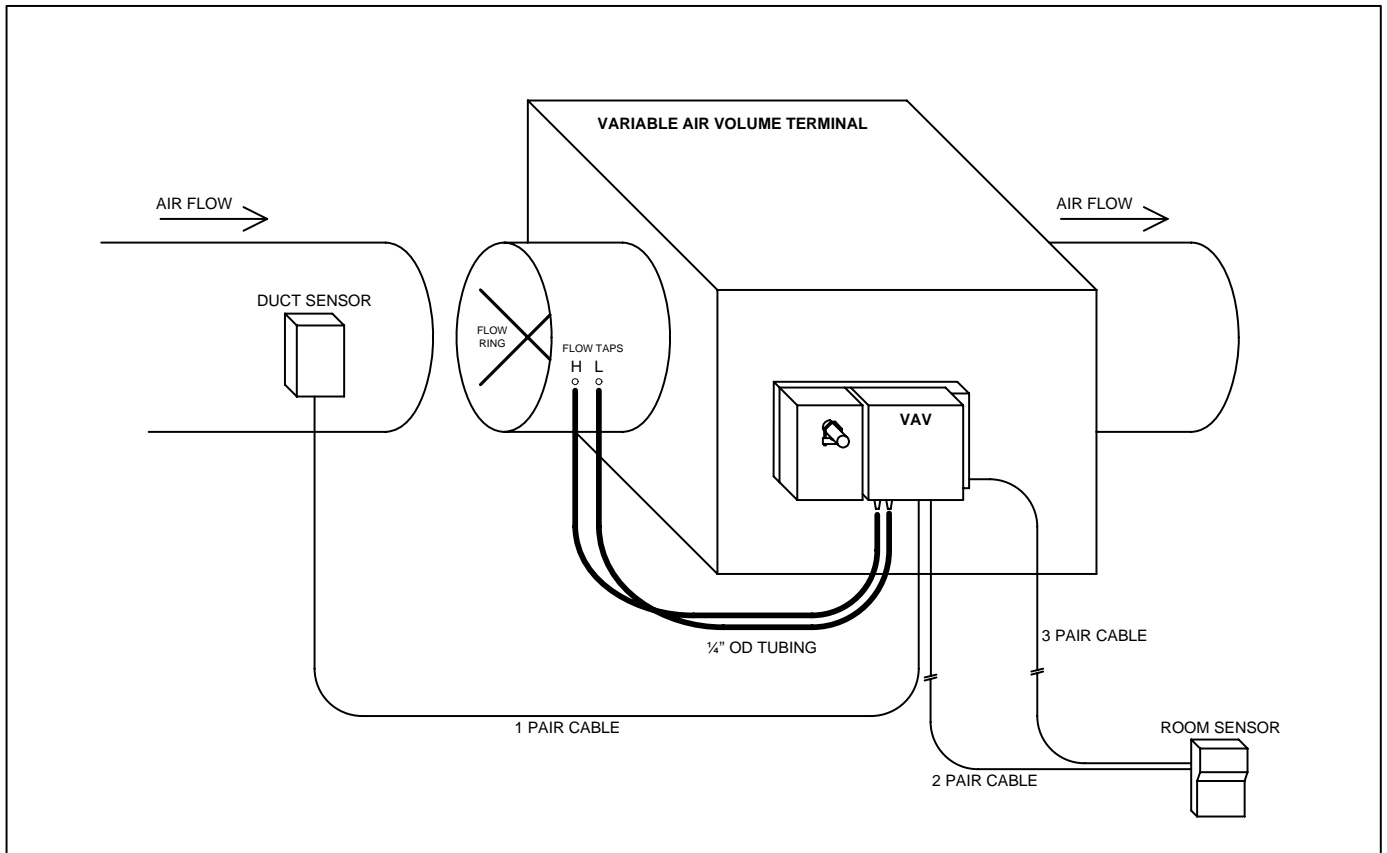

Figure 4: Typical VAV Box Installation

NEW INSTALLATION CW OPEN DAMPER

The VAV assembly operates whereas the Belimo actuator rotates **CLOCKWISE** to open the damper. To connect the actuator to the damper shaft:

1. Turn the damper to the closed position.
2. Press the black triangular shaped clutch on the right edge of the actuator and rotate the actuator fully counter-clockwise.
3. Place the assembly over the damper shaft and hand-tighten the nuts on the actuator V-clamp.
4. Attach the assembly to the box or mounting plate by driving a sheet metal screw through the eyelet on the terminal strip end of the assembly.
3. Lock the actuator to the shaft by tightening the nuts on the V-clamp.
5. Remove the VAV cover and set the address DIP switch as required per **Appendix 1**.
6. Connect the low voltage power to the unit per the next section.
7. Connect temperature sensors per additional sections of this manual.
8. Connect fan or heating stages per additional sections of this manual.
9. Connect modulating reheat valves per additional sections of this manual

NEW INSTALLATION CCW OPEN DAMPER

If the VAV is installed on a box which requires that the damper rotates **COUNTER-CLOCKWISE** to open, connect as follows:

1. Turn the damper to the closed position.
2. Press the black triangular shaped clutch on the right edge of the actuator and rotate the actuator fully clockwise.
3. Place the assembly over the damper shaft and hand-tighten the nuts on the actuator V-clamp.
4. Attach the assembly to the box or mounting plate by driving a sheet metal screw through the eyelet on the terminal strip end of the assembly.
5. Remove the VAV cover and set the address DIP switch as required per **Appendix 1**.
6. Connect the low voltage power to the unit per the next section.
7. Remove and reverse connection of the RED and BLACK wires on the Belimo actuator, where RED is connected to terminal 2 (CCW) and BLACK is connected to terminal 3 (CW).
8. Connect temperature sensors per additional sections of this manual.
9. Connect fan or heating stages per additional sections of this manual.
10. Connect modulating reheat valves per additional sections of this manual

VVR RETROFIT INSTALLATION

The VVR must be mounted in a relatively clean environment, free from major airborne dust and contaminants (moisture, oil, etc.). Keep the VVR away from high voltage equipment that might disrupt communications and away from high vibration equipment. Do not mount the unit near any sources of electromagnetic interference (EMI) or flammable vapors.

Install the VVR controller by attaching the provided snap-track into the unit control enclosure. If no enclosure is provided, mount in standard NEMA 1 box as shown in **Figure 5**.

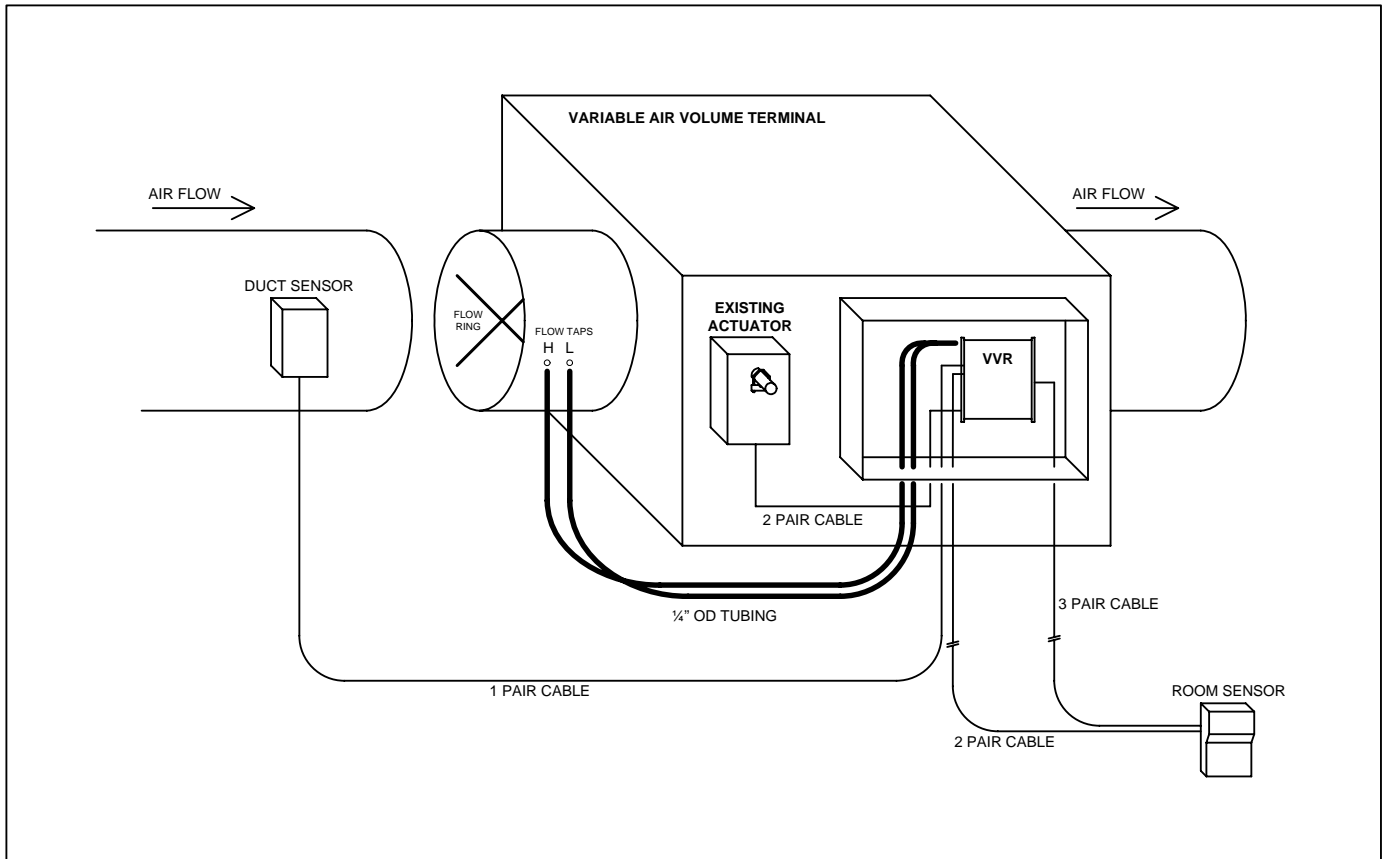

Figure 5: Typical VVR Box Installation

RETROFIT CW OPEN DAMPER

The VVR default logic operates whereas the board activates the **CCW** board output to open the damper. To connect the actuator to the damper shaft to open in a **CLOCKWISE** rotation:

1. Make sure the damper is closed, and the existing actuator is in the full counter-clockwise position.
2. Connect the existing 3-wire floating actuator with 2-pair cable as shown in **Figure 6**.
3. Set the address DIP switch as required per **Appendix 1**.
4. Connect the low voltage power to the unit per the next section.
5. Connect temperature sensors per additional sections of this manual.
6. Connect fan or heating stages per additional sections of this manual.
7. Connect modulating reheat valves per additional sections of this manual

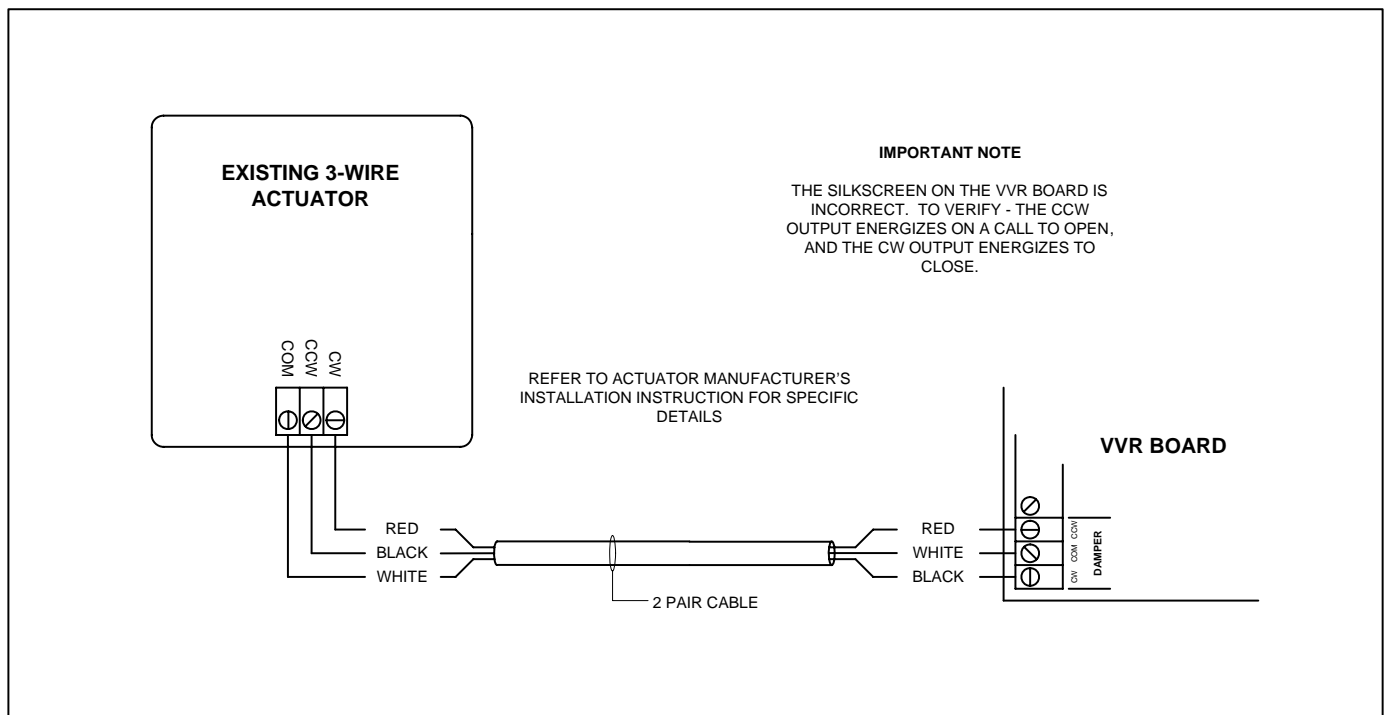

Figure 6: Wiring of Existing Actuator for Clockwise to Open

Actuator Wiring Connections for **CLOCKWISE** to open:

VVR COM	to	ACTUATOR COMMON
VVR CCW	to	ACTUATOR CW
VVR CW	to	ACTUATOR CCW

RETROFIT CCW OPEN DAMPER

If the VVR is installed on a box which requires that the damper rotates **COUNTER-CLOCKWISE** to open, connect as follows:

1. Make sure the damper is closed, and the existing actuator is in the full clockwise position.
2. Connect the existing 3-wire floating actuator with 2-pair cable as shown in **Figure 7**.
3. Set the address DIP switch as required per **Appendix 1**.
4. Connect the low voltage power to the unit per the next section.
5. Connect temperature sensors per additional sections of this manual.
6. Connect fan or heating stages per additional sections of this manual.
7. Connect modulating reheat valves per additional sections of this manual.

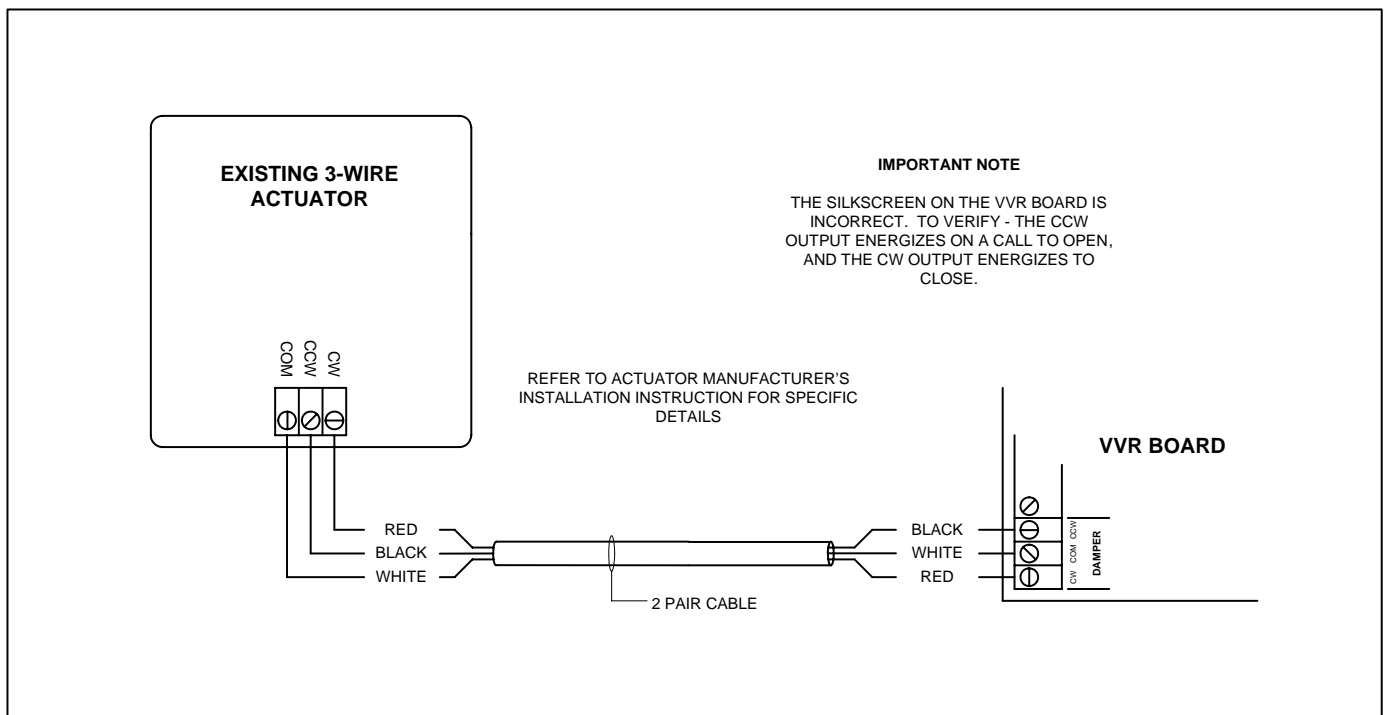

Figure 7: Wiring of Existing Actuator for Counter-Clockwise to Open

Actuator Wiring Connections for **COUNTER-CLOCKWISE** to open:

VVR COM	to	ACTUATOR COMMON
VVR CCW	to	ACTUATOR CCW
VVR CW	to	ACTUATOR CW

CONNECTING THE POWER

The VAV/VVR must be powered by 24VAC Class 2 low voltage transformers. To connect the power wiring to the VAV/VVR, locate the terminals on the outside edge of the VAV/VVR terminal strip and connect to the 24VAC power source. **Figure 8** illustrates the VAV/VVR assembly showing the location of the 24VAC terminal block.

NOTE: For 24 VAC power, use only power supplies with a Class 2 transformer rating.

Do not power with any voltage other than the 24VAC low voltage listed. Connect power to the VAV/VVR by connecting wires from the transformer to the 24VAC terminals L1 and L2. The terminals are labeled on the edge of the VAV/VVR. The red indicator LED under the board clam shell cover will illuminate when the power is properly connected.

For connections to the VAV/VVR, strip the wire back approximately 3/16" and insert into the terminal block. Back out the screw on the terminal block until the bare wire inserts fully, and turn the screw back down until there is firm tension on the wire. Make sure that the clamp secures the stripped portion of the wire, and that no insulation is under the clamp.

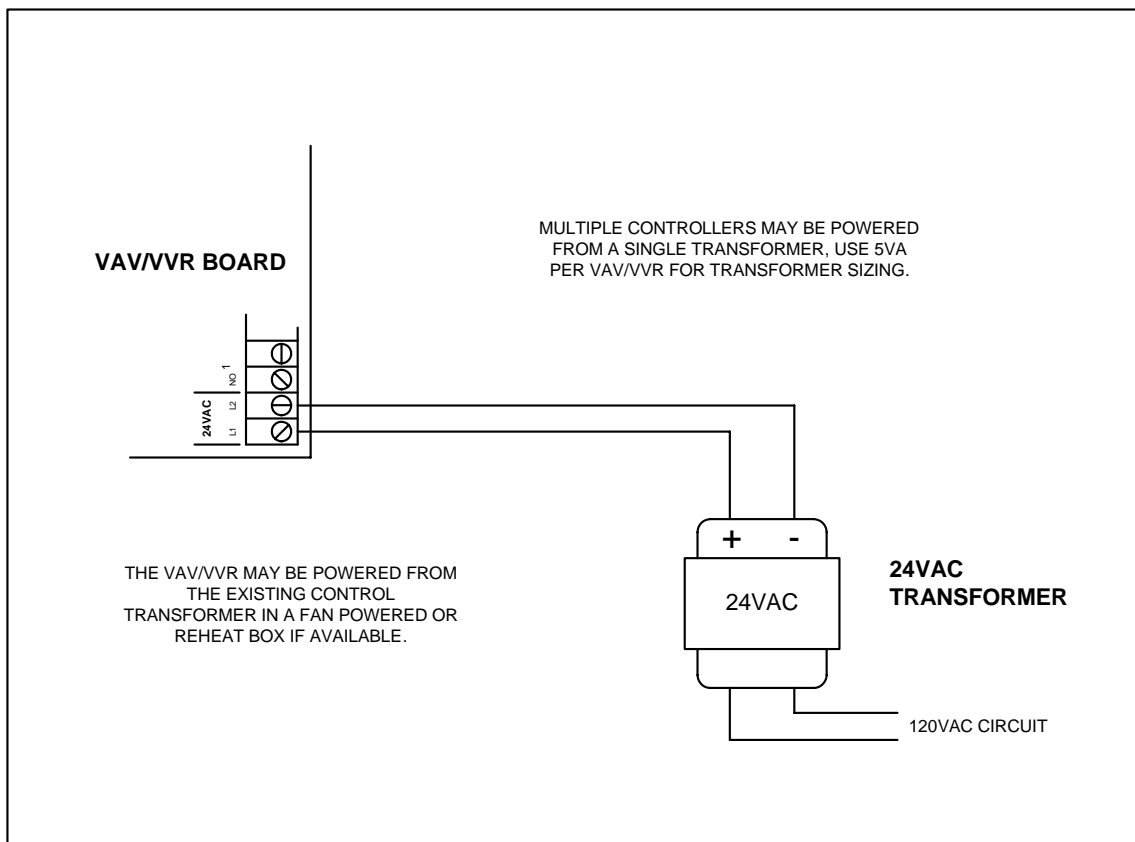

Figure 8: BASYX VAV/VVR power connections

NOTE: Multiple controllers may be powered from a single transformer. Recommend 5VA for transformer sizing when designing power configurations. It is recommended that zones or specific areas are powered in groups, and that not all controllers within the system are powered from a single transformer.

COMMUNICATIONS BUS WIRING

The BASYX VAV/VVR can be used in a stand alone configuration with a wall mounted sensor, with a PSC in smaller applications, or in an array utilizing hundreds of units. When used in an application smaller than 32 total units, a minimum of one (1) PSC must be installed. If used in a large array they must be used in conjunction with the BASYX SCM Supervisor System and the required number of BASYX UBE Communications Expanders. Up to 32 BASYX UBE expander boards can be connected to the BASYX Supervisor. In turn up to 32 BASYX VAV/VVR or other system controllers can be connected to each communication expander providing great flexibility to conform to any building's physical installation requirements.

All communication wiring consists of a shielded, plenum rated cable (See **Figures 9 & 10**). Use 22 AWG, twisted pair, stranded, shielded, plenum rated cable (Recommended Belden 6500FE) for all communications wiring. In lieu of the 6500FE cable, a stranded 2 pair cable with individually paired shields may be used. When connecting a channel of controllers, connect communications in a daisy chain configuration.

Communication is via EIA RS-485 protocol. This requires that the system be wired according to the following methods and rules:

- Communications cable must be 1 twisted pair (Belden 6500FE), 22 AWG, plenum rated.
- The total distance from the UBE expander to the last VAV/VVR in the daisy chain must not exceed 4000 feet.
- The drain wire of the communication cable must **NOT** be connected to the VAV/VVR controller, twist shield wires together to create single shield for the entire daisy chain and connect to ground at one end only (suggest at the UBE location).
- Connection of the REF terminal on the VAV/VVR controller is **NOT** required.
- Each VAV/VVR in the daisy chain must have a unique address. Refer to the instructions below for setting the Device Address (ADDR) dip switch.

Connect the communications wiring to the terminal blocks on the edge of the VAV/VVR assembly marked +, -, and REF as shown in **Figure 9**.

CAUTION: All communication wiring must be connected such that the plus (+) terminal is wired to a plus terminal and the minus terminal (-) is wired to a minus terminal. Do not install communications cables near power cables or in power conduits. Isolate all communications wiring from large motors, fluorescent lighting fixtures or other sources of high intensity electromagnetic interference (EMI).

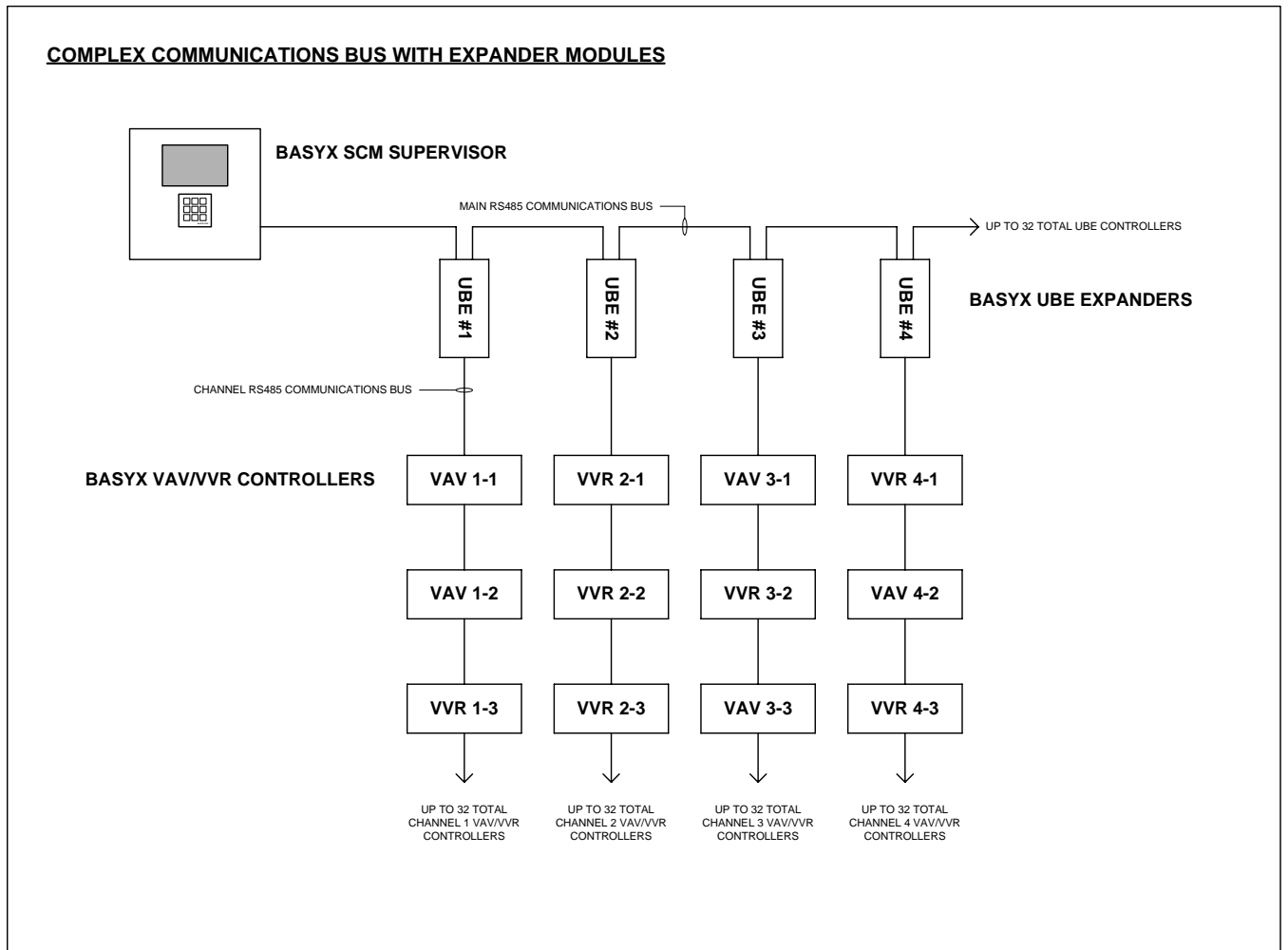

Figure 9: BASYX Typical Communications Loop Configurations

Communications loops may contain any mixture of BASYX controllers. Each controller must have a unique address setting for proper operation.

Smaller systems may not require the BASYX SCM Supervisor or the UBE Unitary Bus Expanders. A Single loop containing a minimum of (1) PSC and up to 31 additional controllers may be used.

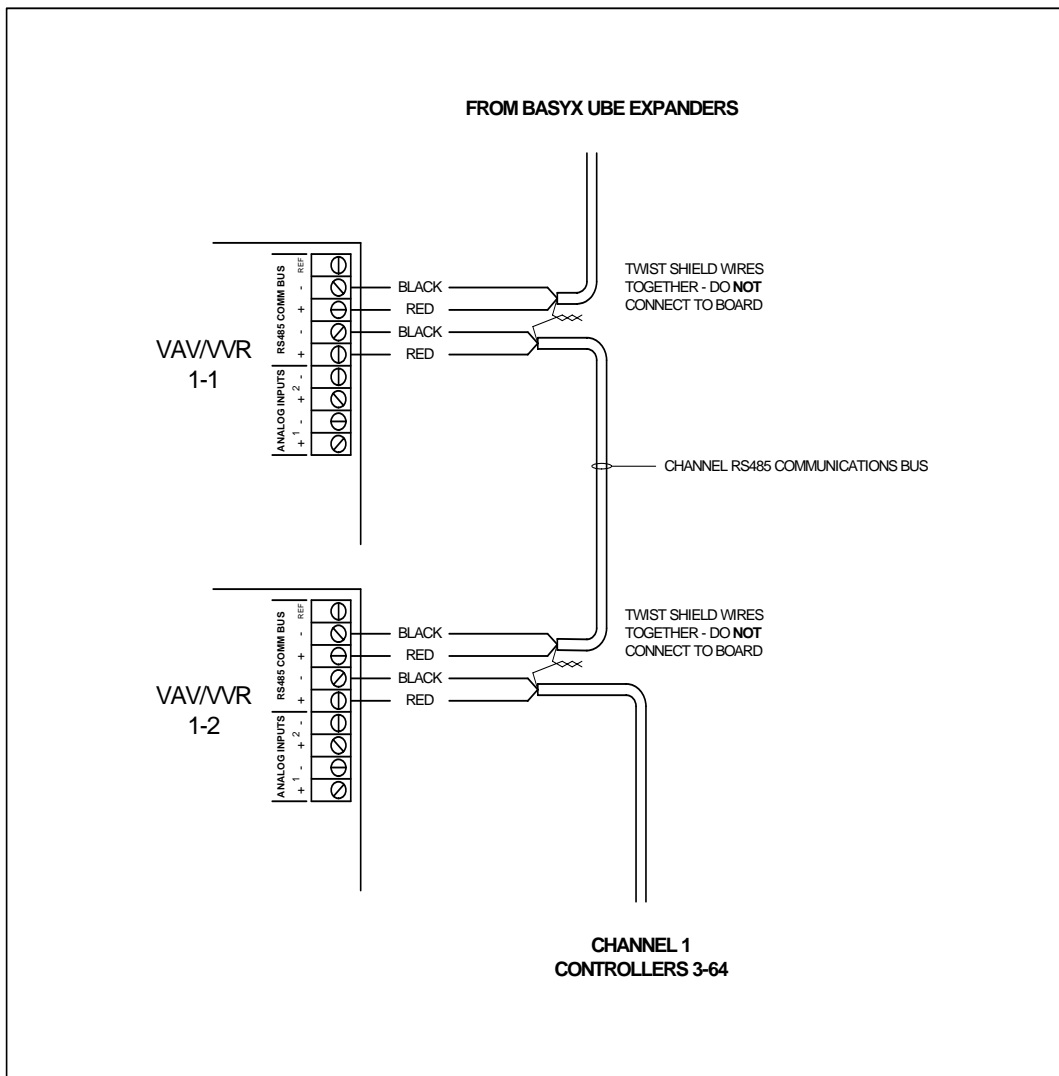

Figure 10: Typical VAV/VVR Communications Connection Details

SETTING THE DEVICE ADDRESS

If the VAV/VVR is used as a stand alone controller make sure that the address is set to #1.

If more than one VAV/VVR is used on the same communications bus then each device must have a different address for proper communication. Removing the clam shell cover from the BASYX VAV assembly will expose the dip switch which sets the individual controller address. Refer to **Appendix 1** for setting the device address to a number between 1 and 64. The communication address for each device must be unique.

NOTE: Do not skip addresses in a daisy chain; begin at 1 and count up. The boards do not have to be in consecutive order, however all addresses must be included.

CONNECTING THE TEMPERATURE SENSORS

The BASYX VAV/VVR provides predetermined analog and digital inputs for variable air volume terminal control. Please refer to the **TYPICAL VAV INSTALLATION DRAWING** at the end of this document for details on complete wiring of the VAV/VVR controller inputs and outputs.

Use 1 pair, shielded plenum cable for all input and output wiring. This cable should be 18 AWG, and should consist of a stranded, twisted-pair, shielded cable with less than 20 pF capacitance per foot.

NOTE: Connect all sensor and output cable drain wires to earth ground.

CAUTION: Do not run sensor or output wires near power cables or in power conduits. Isolate all sensor and output wires from large contactors or motors, fluorescent light fixtures and other sources of high intensity electromagnetic interference (EMI).

SENSOR INPUT DESIGNATIONS

The VAV/VVR analog inputs are thermistor type II only, with inputs dedicated as follows:

- Analog Input 1: Space temperature sensor
- Analog Input 2: Entering supply air temperature sensor
- Analog Input 3: Setpoint adjustment slidebar

Analog input 1 is dedicated for space temperature, and is used for temperature control of the conditioned space, and is used for air flow calculation reset.

Analog input 2 is dedicated to supply air temperature from the corresponding air handling unit. This is used for reversing of damper logic on high supply temperature (morning warmup, etc.), and makes the box a variable air volume heating device based on the adjustable setpoint.

Analog input 3 is the setpoint adjustment slidebar on the ACI/10K-CP-R series room sensor if selected. This is a 0-400 ohm resistance input and will automatically adjust the normal space setpoint by +/- 2 degrees.

CONNECTING THE ROOM SENSOR

The room sensor monitors the space ambient temperature, as well as optional setpoint adjustment and system override function. In addition, the sensor can be provided with an RJ11 jack, which allows connection to the individual controller with a laptop through the room sensor.

Mount the room sensor according to the manufacturer's instructions. Make sure that the sensor is not mounted so that diffuser air is directly hitting the sensor, and that no heat producing equipment is nearby (coffee pots, etc.).

Connect the room sensor as shown in **Figure 11**.

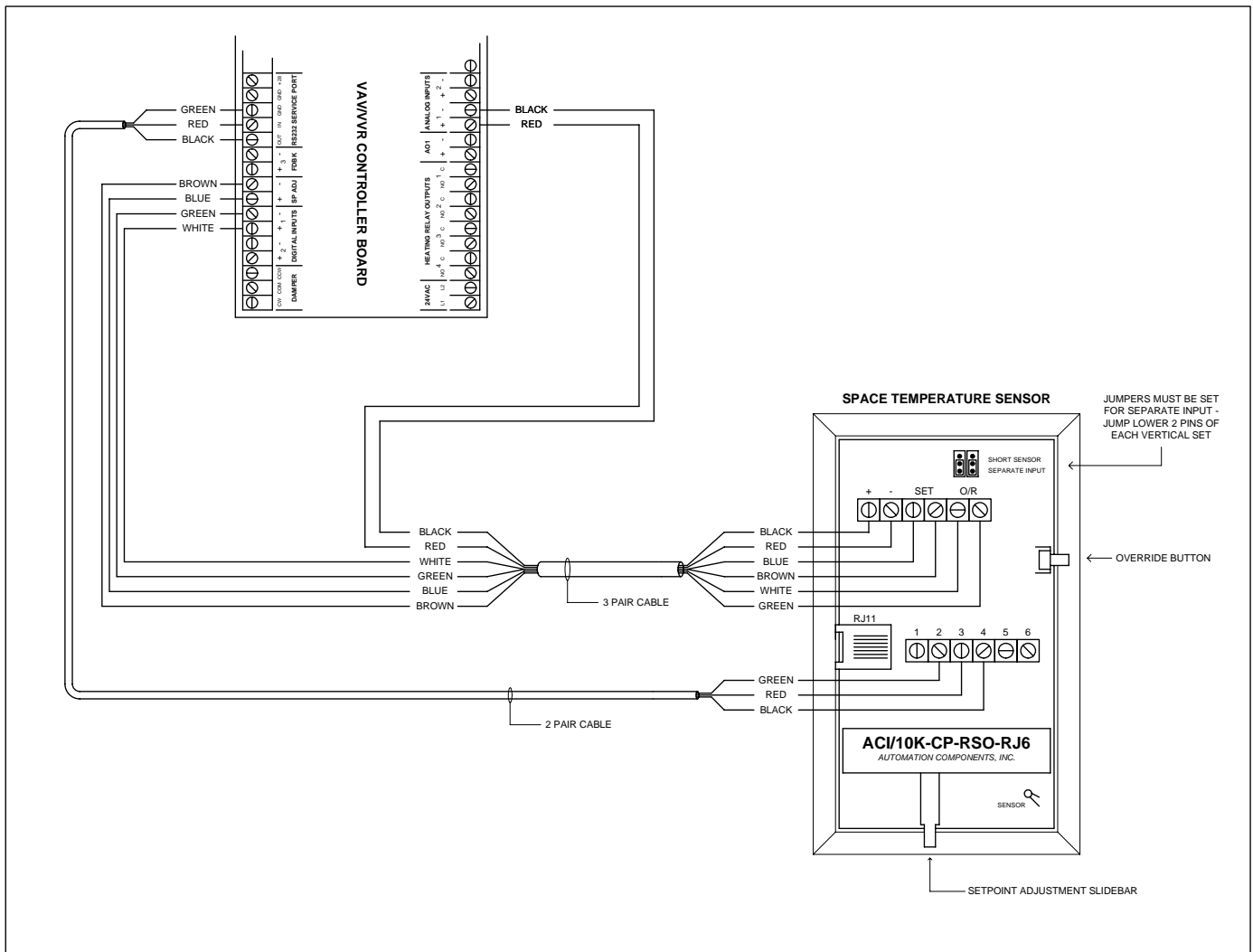

Figure 11: Typical Room Sensor Wiring with Setpoint Adjustment, Override & Direct Connection

CONNECTING THE DUCT SENSOR

The duct sensor monitors the incoming supply air temperature, and allows the reverse operation of the damper upon a high entering duct temperature. This is typically used on air handling equipment with morning warmup function. The reversing function will reverse the operation of the damper i.e. open on a call for heat.

Mount the sensor upstream from the VAV box in the branch duct according to the manufacturer's installation instructions. Make sure that the sensor is in a straight section of duct, and install at least 5 duct diameters ahead of box and away from elbows.

Connect the duct sensor as shown in **Figure 12**.

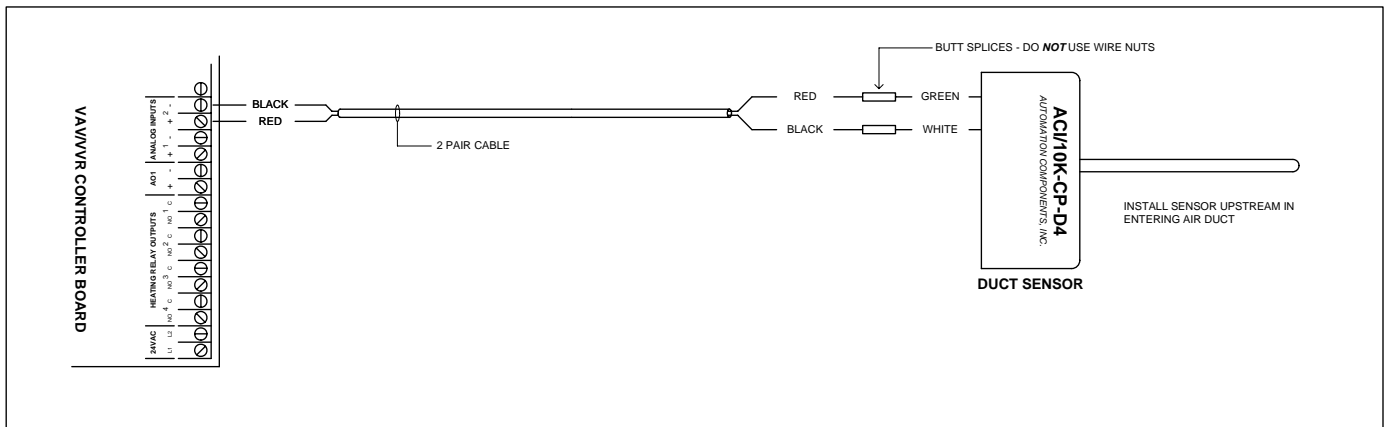

Figure 12: Duct Sensor Wiring

CONNECTING THE DIGITAL INPUTS

The VAV/VVR contains two (2) digital inputs:

Digital Input 1 is dedicated for the override button on the room sensor as shown in **Figure 10**.

Digital Input 2 is a free input, and may be used for monitoring of any dry-contact input. This point may be used to monitor flow switches, current switches, filter switches, etc. and is connected directly next to the override input as shown in **Figure 11**.

CONNECTING THE DIGITAL OUTPUTS

The VAV/VVR provides four (4) SPST relay outputs for control of box fans and/or electric heat strips. The outputs provide a normally open contact, and will interface with most box manufacturer control sequences. **Figure 13** shows output wiring utilizing external pilot relays.

NOTE: The maximum current for each digital output is 1 amp at 24V (AC or DC).

CAUTION: The digital outputs on the VAV/VVR are for low voltage, pilot duty switching. **DO NOT ATTEMPT TO SWITCH LINE VOLTAGE** (120V or higher) through the digital outputs, serious damage may be done to the VAV/VVR controller.

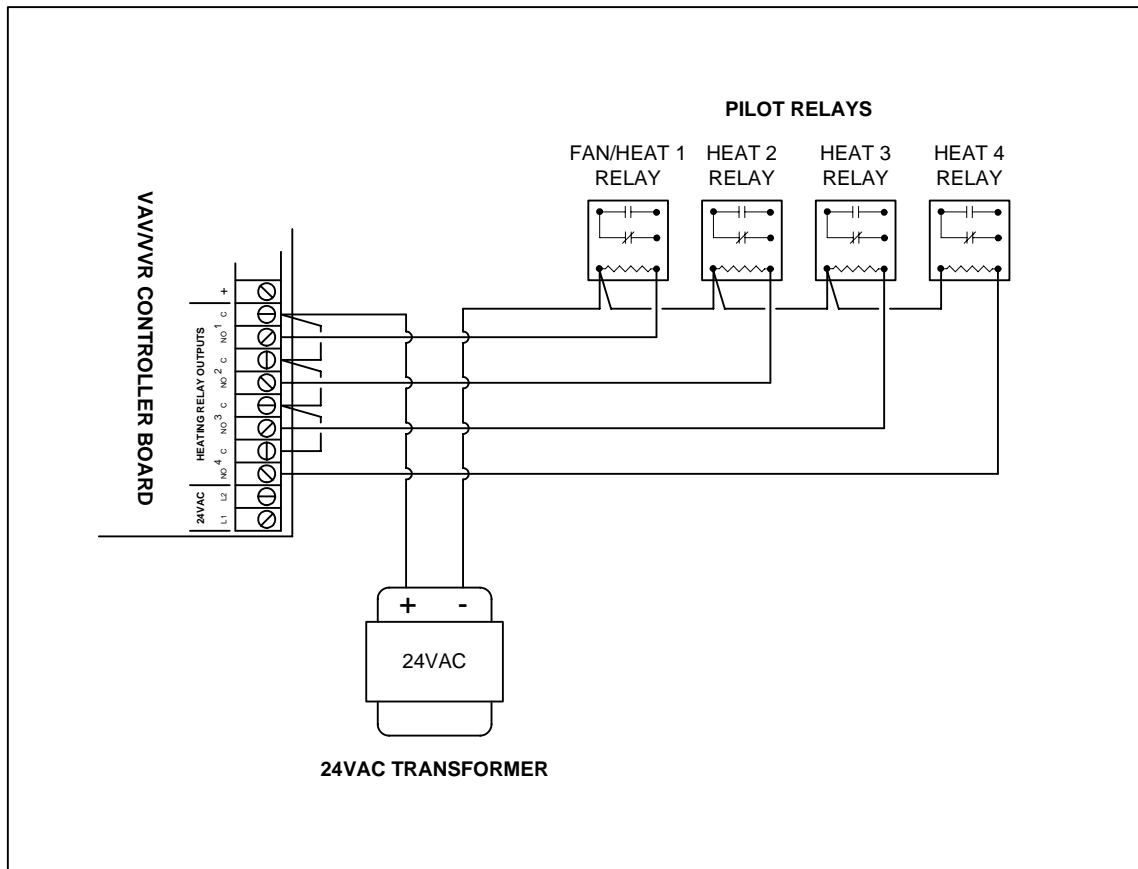

Figure 13: Typical VAV Pilot Relay Output Wiring

Figure 14 shows typical wiring of a fan-powered reheat box which uses the 24VAC transformer in the VAV box controls to power the VAV/VVR board. This is a typical view, and the box manufacturer instructions should be referenced for exact wiring details.

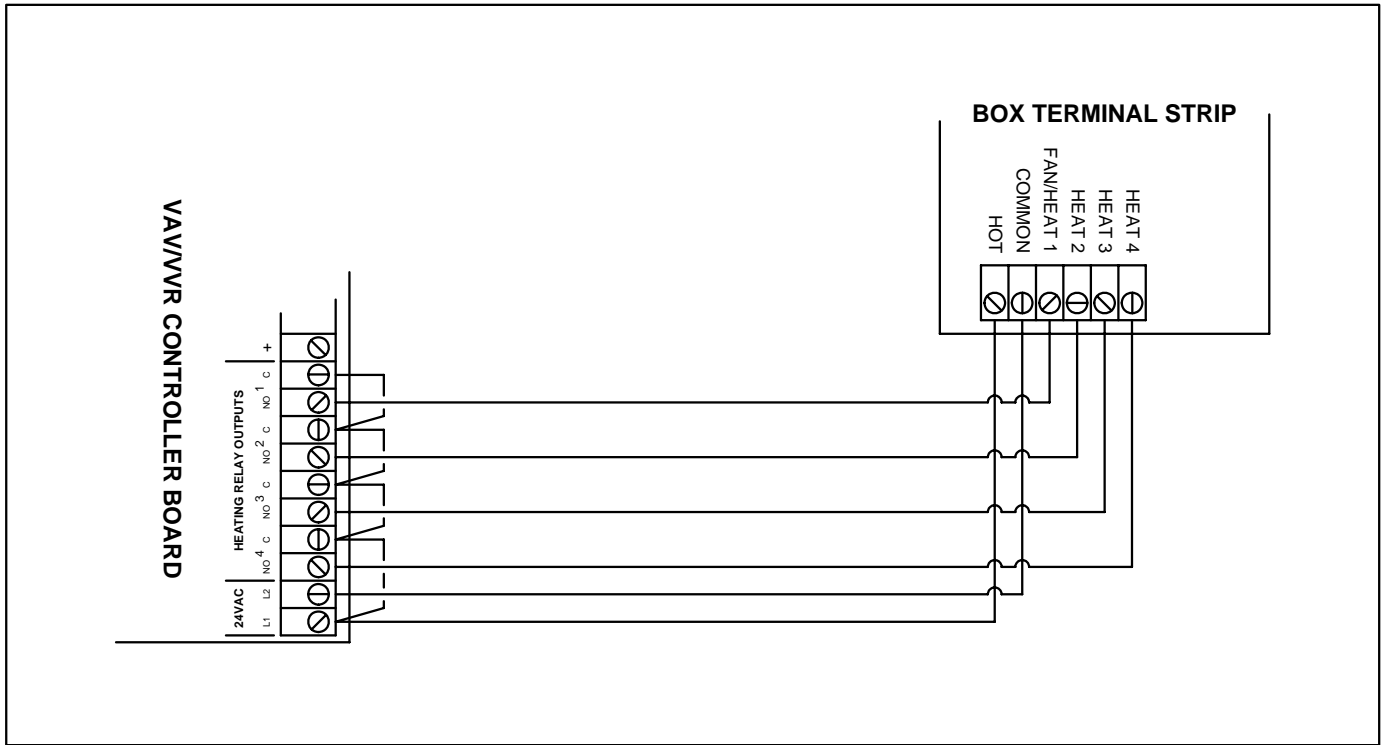

Figure 14: Typical Fan-Powered Box Output Wiring

INSTALLING THE VARISTORS

Each VAV or VVR is shipped with four (4) varistors for installation on existing fan or electric heat contactors. The devices clamp on electrical noise typically associated with drop-out of contactor coil voltage, which may cause the VAV controller to malfunction. To install the varistors, connect in parallel with contactor coil wiring as shown in **Figure 15**.

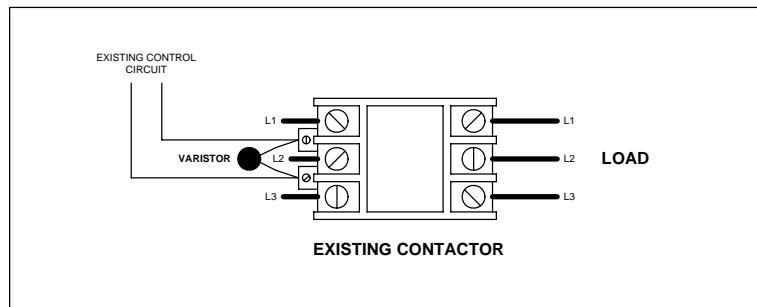

Figure 15: Varistor Installation Details

CONNECTING THE ANALOG OUTPUT

One 0-10vdc analog device may be controlled by the VAV/VVR, and is used to control hot water reheat or baseboard heating valves. **Figure 16** illustrates typical device connections. When connecting the actuator, make sure to be consistent with L1 (HOT) and L2 (COMMON) connections within the system.

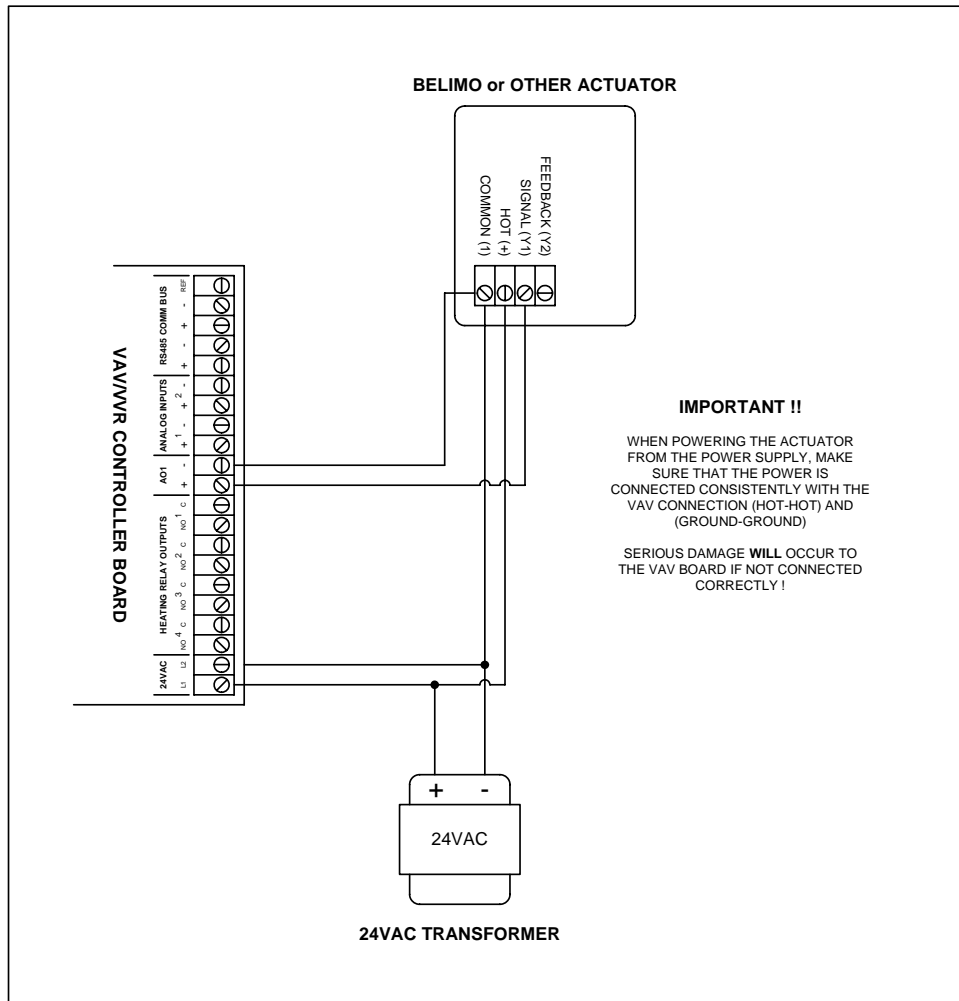

Figure 16: Typical VAV Analog Output Wiring

DANGER: The VAV/VVR analog output is designed for use with an actuator using full-wave power. Serious damage will occur to the VAV/VVR board if connected to a half-wave device. If unsure about your selected actuator, call Triangle MicroSystems technical support.

CONNECTING THE VELOCITY SENSOR

The VAV/VVR uses an on-board differential pressure sensor for monitoring of air flow and velocity of the box discharge to the conditioned space. On the VAV, the sensor is connected with flexible tubing to external taps on the lower edge of the enclosure marked "HIGH" and "LOW". On the VVR, the tubing is connected directly to the velocity sensor at the top of the VVR controller board.

IMPORTANT: When connecting tubing directly to the on-board velocity sensor, the lower (closest to the board) connection is the "LOW" pressure, and the upper connection is the "HIGH".

NOTE: On the VAV assembly, the external taps accept a 1/4" OD tubing.
On the VVR retrofit board, the sensor taps are 3/8" OD.

Figure 17 shows the connection to the box flow ring (see box manufacturers installation manual) or the SSS series flow sensor, which is provided for older boxes without a flow ring, or damper blade only type installations.

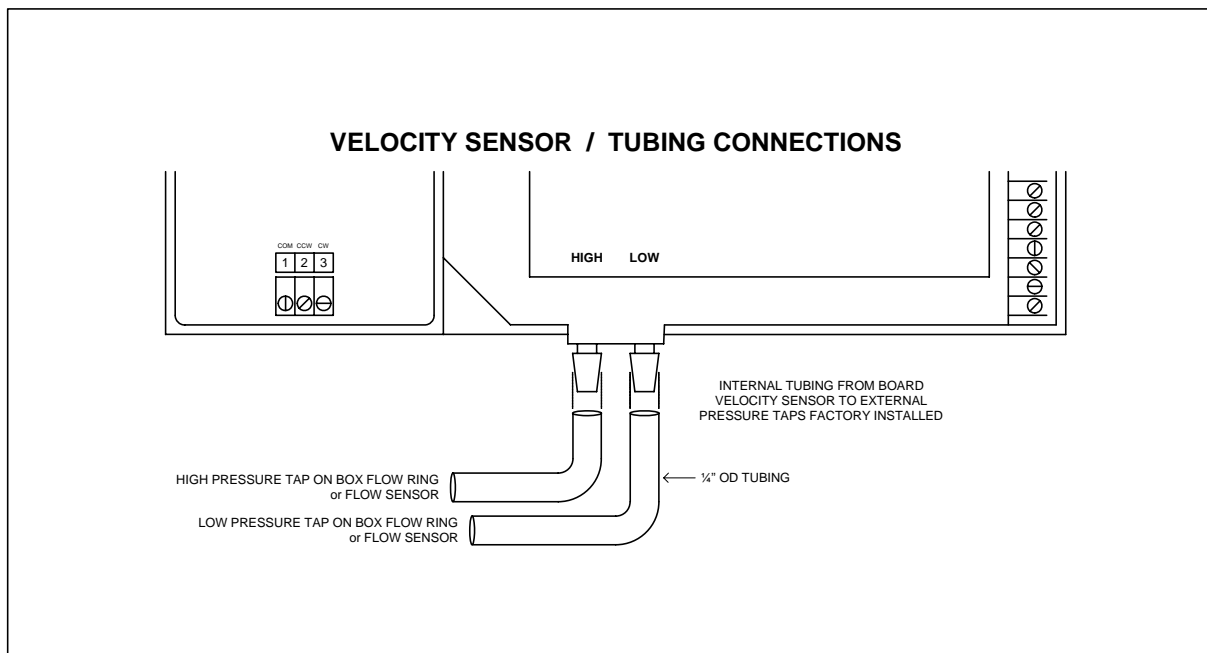

Figure 17: Typical VAV Velocity Sensor Tubing Connections

NOTE: See **Appendix 2** for box constant values for major manufacturers

OPERATION

The red indicator light next to the 24VAC terminal block illuminates solid when the power is on. When the unit is operating properly, the two (2) CPU lights will blink intermittently to indicate proper CPU operation.

BASIC TROUBLESHOOTING

If the VAV/VVR does not operate properly, perform the necessary troubleshooting as described below.

SYMPTOM

ACTION

Failure to communicate:

Check that the power is on and that the red indicator light is on.
If it is on, measure voltage at the 24VAC power terminals of the VAV to ensure that the unit is getting 24VAC (-10% / +5%).
Check the continuity and connection of the communication wires.
Check that the device address is correctly set.

Faulty Communication:

Check that all communication cables are connected as required, with drain wires connected to a solid earth ground.
Check that all communication cable wires are connected “+” terminal to “+” terminal and “-” terminal to “-” terminal.
Check for continuity on all communication signal lines.
Isolate sensor wiring from large contactors, fluorescent light fixtures, and other sources of high-intensity electromagnetic interference (EMI).

Digital outputs not responding:

Disconnect the device wiring and check for continuity at the between common (C) and normally open (NO) terminals based on output position.
Check to see that exterior voltage source is present if used to switch pilot relays.

Analog or digital inputs are jumpy:

Isolate sensor wiring from large contactors, motors, fluorescent light fixtures, and other sources of high-intensity electromagnetic interference (EMI).

SPECIFICATIONS

Communication:	EIA RS-485 at 9600 baud on 22AWG shielded, plenum rated cable (recommended Belden 6500FE or equivalent)	
Power Requirements:	24VAC (-10% / 5%), 50/60/Hz 3.2VA for VAV 2.4VA plus actuator current for VVR Recommend 5VA transformer sizing for AC power	
Analog Inputs:	(3) 10K ohm thermistor	Type II.
Digital Inputs:	(2) Dry contacts	>= 50ms timing
Analog Outputs:	(1) 0-10VDC	>= 1K ohm drive impedance
Digital Outputs:	(4) Dry contacts	SPST pilot duty 1 amp at 24VAC or 24VDC
Environmental Limits:	Temperature:	32°F to 125°F.
	Humidity (non-condensing):	95%
UL Listing:	ANSI/UL 916	
Dimensions:	VAV: 9.0"W x 5.0"H x 2.5"D	VVR: 4.5"W x 4.0"H x 1.75"D
Shipping Weight:	VAV: Approx. 1.95 lbs.	VVR: Approx. 0.5 lbs.

ABOUT THE BASYX PRODUCT LINE

The VAV/VVR is one product in a line of BASYX control products. The TriComm interface software package is a Windows based human interface used with the BASYX automation and control system. Tricomm will operate on any personal computer with the Windows 95,95,ME,NT,2000 or XP operating system.

The program provides a simple interface through direct connect, modem or internet to setup, operate and modify the operating parameters of the BASYX system, using easy to understand point-and-click commands. The drop-down system menus allow access to all system functions, and requires minimal computer experience for normal daily interaction with the system.

The BASYX system is designed specifically to meet today's building automation, facility and energy management needs. Triangle MicroSystems, Inc. develops and provides application support for control systems around the world. The company has a continuing commitment to research and development in order to provide new and improved products to the building automation market.

For more information contact:

Triangle MicroSystems, Inc.
Building Controls Division
2716 Discovery Drive
Raleigh, NC 27616-1852

Telephone: (919) 878-1880
Toll-Free: (800) 334-5548
Fax: (919) 872-2071

E-mail: sales@tms-nc.com
Website: www.tms-nc.com

The technical contents of this document, while accurate as of publication, are subject to change without notice.
No responsibility is assumed for its use.

APPENDIX 1 - BASYX ADDRESS SWITCH SETTINGS

ADDRESSES 1-32

ADDRESS	SW 1	SW 2	SW 3	SW 4	SW 5	SW 6	SW 7	SW 8
1	ON	OFF	OFF	OFF	OFF	OFF	OFF	OFF
2	OFF	ON	OFF	OFF	OFF	OFF	OFF	OFF
3	ON	ON	OFF	OFF	OFF	OFF	OFF	OFF
4	OFF	OFF	ON	OFF	OFF	OFF	OFF	OFF
5	ON	OFF	ON	OFF	OFF	OFF	OFF	OFF
6	OFF	ON	ON	OFF	OFF	OFF	OFF	OFF
7	ON	ON	ON	OFF	OFF	OFF	OFF	OFF
8	OFF	OFF	OFF	ON	OFF	OFF	OFF	OFF
9	ON	OFF	OFF	ON	OFF	OFF	OFF	OFF
10	OFF	ON	OFF	ON	OFF	OFF	OFF	OFF
11	ON	ON	OFF	ON	OFF	OFF	OFF	OFF
12	OFF	OFF	ON	ON	OFF	OFF	OFF	OFF
13	ON	OFF	ON	ON	OFF	OFF	OFF	OFF
14	OFF	ON	ON	ON	OFF	OFF	OFF	OFF
15	ON	ON	ON	ON	OFF	OFF	OFF	OFF
16	OFF	OFF	OFF	OFF	ON	OFF	OFF	OFF
17	ON	OFF	OFF	OFF	ON	OFF	OFF	OFF
18	OFF	ON	OFF	OFF	ON	OFF	OFF	OFF
19	ON	ON	OFF	OFF	ON	OFF	OFF	OFF
20	OFF	OFF	ON	OFF	ON	OFF	OFF	OFF
21	ON	OFF	ON	OFF	ON	OFF	OFF	OFF
22	OFF	ON	ON	OFF	ON	OFF	OFF	OFF
23	ON	ON	ON	OFF	ON	OFF	OFF	OFF
24	OFF	OFF	OFF	ON	ON	OFF	OFF	OFF
25	ON	OFF	OFF	ON	ON	OFF	OFF	OFF
26	OFF	ON	OFF	ON	ON	OFF	OFF	OFF
27	ON	ON	OFF	ON	ON	OFF	OFF	OFF
28	OFF	OFF	ON	ON	ON	OFF	OFF	OFF
29	ON	OFF	ON	ON	ON	OFF	OFF	OFF
30	OFF	ON	ON	ON	ON	OFF	OFF	OFF
31	ON	ON	ON	ON	ON	OFF	OFF	OFF
32	OFF	OFF	OFF	OFF	OFF	ON	OFF	OFF

ADDRESSES 33-64:

ADDRESS	SW 1	SW 2	SW 3	SW 4	SW 5	SW 6	SW 7	SW 8
33	ON	OFF	OFF	OFF	OFF	ON	OFF	OFF
34	OFF	ON	OFF	OFF	OFF	ON	OFF	OFF
35	ON	ON	OFF	OFF	OFF	ON	OFF	OFF
36	OFF	OFF	ON	OFF	OFF	ON	OFF	OFF
37	ON	OFF	ON	OFF	OFF	ON	OFF	OFF
38	OFF	ON	ON	OFF	OFF	ON	OFF	OFF
39	ON	ON	ON	OFF	OFF	ON	OFF	OFF
40	OFF	OFF	OFF	ON	OFF	ON	OFF	OFF
41	ON	OFF	OFF	ON	OFF	ON	OFF	OFF
42	OFF	ON	OFF	ON	OFF	ON	OFF	OFF
43	ON	ON	OFF	ON	OFF	ON	OFF	OFF
44	OFF	OFF	ON	ON	OFF	ON	OFF	OFF
45	ON	OFF	ON	ON	OFF	ON	OFF	OFF
46	OFF	ON	ON	ON	OFF	ON	OFF	OFF
47	ON	ON	ON	ON	OFF	ON	OFF	OFF
48	OFF	OFF	OFF	OFF	ON	ON	OFF	OFF
49	ON	OFF	OFF	OFF	ON	ON	OFF	OFF
50	OFF	ON	OFF	OFF	ON	ON	OFF	OFF
51	ON	ON	OFF	OFF	ON	ON	OFF	OFF
52	OFF	OFF	ON	OFF	ON	ON	OFF	OFF
53	ON	OFF	ON	OFF	ON	ON	OFF	OFF
54	OFF	ON	ON	OFF	ON	ON	OFF	OFF
55	ON	ON	ON	OFF	ON	ON	OFF	OFF
56	OFF	OFF	OFF	ON	ON	ON	OFF	OFF
57	ON	OFF	OFF	ON	ON	ON	OFF	OFF
58	OFF	ON	OFF	ON	ON	ON	OFF	OFF
59	ON	ON	OFF	ON	ON	ON	OFF	OFF
60	OFF	OFF	ON	ON	ON	ON	OFF	OFF
61	ON	OFF	ON	ON	ON	ON	OFF	OFF
62	OFF	ON	ON	ON	ON	ON	OFF	OFF
63	ON	ON	ON	ON	ON	ON	OFF	OFF
64	OFF	OFF	OFF	OFF	OFF	OFF	ON	OFF

APPENDIX 2 - MANUFACTURER BOX CONSTANTS

The following tables show flow calculation constants for the most commonly used manufacturers of variable air volume terminals.

Manufacturers Listed:

Carnes Company
 Environmental Technologies, Inc. (ETI)
 Krueger
 Metal Industries
 Price Industries
 Redd-I
 Trane Company
 Temperature Industries
 Titus
 Tuttle & Bailey
 York Industries
 Damper Only Installations

Although accurate at the time of publication, these numbers are subject to change without notice. Consult the manufacturer's technical data for further information on your particular box.

CARNES COMPANY

Box Type & Model	Inlet Size (in.)	CFM @ 1"	Area	K (Box Constant)
Single Duct: AVCC / AVWC / AVEC	5" Round	NA	0.136	2.42
	6" Round	NA	0.196	2.37
Constant Fan: ACFB	7" Round	NA	0.267	2.40
	8" Round	NA	0.349	2.41
	10" Round	NA	0.545	2.61
Intermittent Fan: ASFB	12" Round	NA	0.785	2.35
	14" Round	NA	1.068	2.42
Dual Duct: ADCC	16" Round	NA	1.396	2.38
	9 x 12	NA	0.750	2.37
	16 x 18	NA	2.000	2.30
	<i>90 deg travel, clockwise to close</i>	16 x 24	NA	2.670

ENVIRONMENTAL TECHNOLOGIES

Box Type & Model	Inlet Size (in.)	CFM @ 1"	Area	K (Box Constant)
Models: SDR / CFR / VFR Newer style as of 10/92 <i>90 deg travel, clockwise to close</i>	4" Round	248	0.079	1.628
	5" Round	392	0.126	1.657
	6" Round	433	0.184	2.896
	8" Round	841	0.333	2.515
	10" Round	1355	0.525	2.408
	12" Round	1976	0.761	2.379
	14" Round	2750	1.040	2.294
	16" Round	3596	1.360	2.294
	19" Round	6377	2.720	2.918
	22" Round	8760	3.555	2.642
Models: SSD / CVF / VVF / SDD Older style prior to 10/92 <i>45 deg travel, clockwise to close</i>	4" Round	276	0.09	1.71
	5" Round	431	0.14	1.69
	6" Round	620	0.20	1.67
	8" Round	1104	0.35	1.61
	10" Round	1631	0.52	1.63
	12" Round	2180	0.69	1.61
	14" Round	2728	0.86	1.59
	16" Round	3280	1.04	1.61
	18" Round	3840	1.21	1.59
	20" Round	4634	1.47	1.61
24" Round	5797	1.83	1.60	

KRUEGER

Box Type & Model	Inlet Size (in.)	CFM @ 1"	Area	K (Box Constant)
Single Duct Cooling Only: DLMHS	4" Round	235	0.09	2.35
	5" Round	375	0.14	2.36
	6" Round	530	0.20	2.28
Fan Powered Series Fan: DQFC / QFC-Q <i>90 deg travel, clockwise to close</i>	7" Round	730	0.27	2.19
	8" Round	945	0.35	2.20
	9" Round	1200	0.44	2.16
	10" Round	1450	0.55	2.31
	12" Round	2150	0.79	2.16
	14" Round	2950	1.07	2.11
	16" Round	3800	1.40	2.18
	24 x 16	7250	2.60	2.06

METAL INDUSTRIES

Box Type & Model	Inlet Size (in.)	CFM @ 1"	Area	K (Box Constant)
All models: 400th Series	6" Round	580	0.20	1.91
	8" Round	980	0.35	2.10
	10" Round	1540	0.53	1.89
<i>90 deg travel, either direction to close</i>	12" Round	2000	0.77	2.38
	14" Round	2590	0.96	2.20
	16" Round	3200	1.18	2.18

PRICE INDUSTRIES

Box Type & Model	Inlet Size (in.)	CFM @ 1"	Area	K (Box Constant)
Single Duct Cooling Only: SDV5000/8000	4" Round	315	0.09	1.31
	5" Round	450	0.14	1.55
	6" Round	570	0.20	1.97
Fan Powered Series Fan: FDC5000/8000	7" Round	790	0.27	1.87
	8" Round	1025	0.35	1.87
Fan Powered Parallel Fan: FDV5000/8000	9" Round	1325	0.44	1.78
	10" Round	1650	0.55	1.78
Dual Duct: DDV5000/8000	12" Round	2450	0.79	1.67
	14" Round	3500	1.07	1.50
	16" Round	4600	1.40	1.50
<i>90 deg travel, counter clockwise to close</i>	24 x 16	8600	2.67	1.54

REDD-I

Box Type & Model	Inlet Size (in.)	CFM @ 1"	Area	K (Box Constant)
All Box Types	6" Round	518	0.20	2.39
	8" Round	824	0.35	2.89
	10" Round	1276	0.55	2.98
	12" Round	1895	0.79	2.79
<i>45 deg travel, either direction to close</i>	14" Round	2630	1.07	2.65
	16" Round	3540	1.40	2.51

TRANE COMPANY

Box Type & Model	Inlet Size (in.)	CFM @ 1"	Area	K (Box Constant)
Single Duct: VCCD / ED / WD / VSSD / VCCE WE / EE	4" Round	310	0.14	3.27
	6" Round	482	0.20	2.65
	8" Round	898	0.35	2.44
	10" Round	1439	0.55	2.30
Fan Powered Series Fan: VSCD / ED / WD / VFPE	12" Round	2086	0.79	2.30
	14" Round	2823	1.07	2.30
	16" Round	3719	1.40	2.27
Fan Powered Parallel Fan: VFCD / ED / WD / VFPE				
Dual Duct: VCDD / VDDD				

TEMPERATURE INDUSTRIES

Box Type & Model	Inlet Size (in.)	CFM @ 1"	Area	K (Box Constant)
Single Duct Cooling Only: S-7 / V / 2 / HS	5" Round	440	0.14	1.62
	6" Round	600	0.20	1.78
	7" Round	850	0.27	1.62
Fan Powered Series Fan: FCN / FCE / FCW HFS / HVFS	8" Round	1200	0.35	1.36
	10" Round	1700	0.55	1.68
	12" Round	1900	0.79	2.77
Fan Powered Parallel Fan: HFB / HVFB	14" Round	2750	1.07	2.43
	16" Round	3300	1.40	2.89
	Dual Duct: SX	18" Round	5500	1.77
	20" Round	6600	2.18	1.75
<i>60 deg travel, counter clockwise to close</i>	24" Round	9500	3.14	1.75

TITUS

Box Type & Model	Inlet Size (in.)	CFM @ 1"	Area	K (Box Constant)
Single Duct Cooling Only: DESV3000	4" Round	244	0.09	2.04
	5" Round	381	0.14	2.04
	6" Round	470	0.20	2.79
Fan Powered Series Fan: DFPC / DMFC	7" Round	601	0.27	3.17
	8" Round	838	0.35	2.78
Fan Powered Parallel Fan: DMFV	9" Round	995	0.44	3.16
	10" Round	1308	0.55	2.78
	Dual Duct: DEDV / DEDC	12" Round	1884	0.79
14" Round		2566	1.07	2.78
<i>90 deg travel, clockwise to close</i>		16" Round	3350	1.40

TUTTLE & BAILEY

Box Type & Model	Inlet Size (in.)	CFM @ 1"	Area	K (Box Constant)	
All Models: SDV / FPC / FPV / HPV / DDV / RV	4" Round	209	0.090	2.97	
	5" Round	315	0.136	2.99	
	6" Round	462	0.196	2.89	
	7" Round	612	0.267	3.05	
	8" Round	817	0.349	2.93	
	10" Round	1249	0.545	3.05	
	<i>60 deg travel, counter clockwise to close</i>	12" Round	1792	0.785	3.08
		14" Round	2474	1.068	2.99
		16" Round	3235	1.396	2.99
	18" Round	4117	1.767	2.95	
Exhaust Boxes Orifice Ring: RR	4" Round	235	0.090	2.35	
	5" Round	388	0.136	1.97	
	6" Round	569	0.196	1.90	
	7" Round	792	0.267	1.82	
	8" Round	1079	0.349	1.68	
	10" Round	1585	0.545	1.90	
	12" Round	2271	0.785	1.92	
	14" Round	2978	1.068	2.06	
	16" Round	4057	1.396	1.90	
	18" Round	5161	1.767	1.88	

YORK

Box Type & Model	Inlet Size (in.)	CFM @ 1"	Area	K (Box Constant)
Single Duct Cooling Only: TSNQ / TSEQ / TSW/TSN	5" Round	440	0.14	1.62
	6" Round	600	0.20	1.78
	7" Round	850	0.27	1.62
	8" Round	1200	0.35	1.36
Fan Powered Series Fan: FCN / FCE / FCW	10" Round	1700	0.55	1.68
	12" Round	1900	0.79	2.77
Fan Powered Parallel Fan: FV / FVE / FVW FVN	14" Round	2750	1.07	2.43
	16" Round	3300	1.40	2.89
	18" Round	5500	1.77	1.66
	20" Round	6600	2.18	1.75
<i>60 deg travel, counter clockwise to close</i>	24" Round	9500	3.14	1.75

DAMPER ONLY INSTALLATIONS
 In-Line Dampers or Boxes Without Flow Ring

Box Type & Model	Inlet Size (in.)	CFM @ 1"	Area	K (SSE Sensor)
In-Line Round Damper	4" Round	125	0.09	1.00
	5" Round	220	0.14	1.00
	6" Round	360	0.20	1.00
Boxes without Flow Ring	7" Round	550	0.27	1.00
	8" Round	800	0.35	1.00
	9" Round	1025	0.44	1.00
	10" Round	1400	0.55	1.00
	12" Round	2300	0.79	1.00
	14" Round	3500	1.07	1.00
	16" Round	5000	1.40	1.00

APPENDIX 3 - RECOMMENDED CABLE

This document lists the recommended cable types and part numbers for the various connections to the BASYX building automation and control system hardware. TMS recommends the New Generation product line from Belden Wire & Cable, and suggests that any substitutions meet or exceed the technical specifications of those cables listed.

Communications Cable

Belden 6500FE	1 twisted, shielded pair 22 AWG, Plenum rated	Communications
Belden 6541FE	2 twisted pairs w/overall shield 22 AWG, Plenum rated	Communications

Sensor & Output Cable

Belden 6300FE	1 twisted pair w/overall shield 18 AWG, Plenum rated	Sensors & Outputs
Belden 6342FE	3 twisted pairs w/overall shield 18 AWG, Plenum rated	Sensors & Outputs
Belden 6343FE	4 twisted pairs w/overall shield 18 AWG, Plenum rated	Sensors & Outputs
Belden 6345FE	6 twisted pairs w/overall shield 18 AWG, Plenum rated	Sensors & Outputs
Belden 6347FE	9 twisted pairs w/overall shield 18 AWG, Plenum rated	Sensors & Outputs

Specialty Cable

Belden 6541FE	2 twisted pairs w/overall shield 22 AWG, Plenum rated	Room Sensor RJ11 Jack
Belden 6542FE	3 twisted pairs w/overall shield 22 AWG, Plenum rated	Room Sensor R / RS / RO / RSO

Multi-paired cable should be used for ALL connections to the BASYX system, multi-conductor cable should be avoided due to capacitance issues. ALL cables should be shielded type, and drain wires should be connected to solid earth ground.