

TMS Installation Instructions

for TMS MPC-162 Control Systems connecting to Tokheim 162 Pumps and Dispensers

Read This Book

This book has important information for safe installation and operation of this equipment. Read and understand this book before applying power. Keep this book and tell all service personnel to read this book. **If you do not follow the instructions, you can cause damage to the equipment, injury, or death.**

Triangle Microsystems Inc.
2716 Discovery Drive
Raleigh, N.C. 27616
TMS ---- 06.05.2004

TABLE OF CONTENTS

	PAGE
TMS MPC-162 SYSTEM DESCRIPTION	3
SYSTEM DIAGRAM (FIGURE 1)	4
SYSTEM POWER REQUIREMENTS	5
ENVIRONMENTAL REQUIREMENTS	5
CONSOLE TO INTERCONNECT BOX CONNECTION	5
DIMENSIONS	5
WEIGHT	5
PERIPHERAL INTERFACE INSTALLATION	5
TMS MPC-162 IC BOX DESCRIPTIONS	6
DANGERS, WARNINGS, CAUTIONS	7
CONNECTION INSTRUCTIONS	8
A.C. POWER REQUIREMENTS	8
INSTALLATION SEQUENCE	8
MECHANICAL CABLE CONNECTION	9
MPC-TM96 PUMP CARD INSTALLATION	10
IC BOX CONNECTION INSTRUCTIONS	10
PROGRAMMING INSTRUCTIONS FOR MPC-TM96 PUMP CARDS	11
MPC-TM96 PUMP CARD SWITCH DESCRIPTION	12
IMPORTANT NOTES	13
162 DISPENSER HOOKUP	14
162 SUCTION HOOKUP	15
START-UP PROCEDURE	16
IN CASE OF EMERGENCY POWER DOWN INSTRUCTIONS	16
SERVICE AND WARRANTY INFORMATION	17-18

TMS MPC-162 SYSTEM DESCRIPTION

The TMS MPC-162 system is designed to control Tokheim Model 162 electronic pumps/dispensers. MPC Systems are sold in 8 or 16 fueling position configurations, and are capable of controlling any combination of 162, 262A, TCS, TCSA, and Premier pumps/dispensers (up to four grades per side). This includes blend style pumps/dispensers, and all can be controlled from a single IC box. In addition, the MPC console, when configured as a **HYBRID**, can simultaneously control mechanical pumps/dispensers via the standard TMS-800F interconnect box. Figure 1, on page 2, shows a TMS MPC-162 system diagram with one Tokheim MPD and 162 connected.

NOTE: The TMS MPC electronic control systems DO NOT INTERFACE with Tokheim MMDs or NON-A versions of the 262.

A system for controlling from ~~one to four 162 fueling positions~~ consists of an MPC console, MPC cable, and a main TMS MPC-162 Interconnect Box. The main IC Box can hold two MPC-96 pump cards, and each MPC-TM96 pump card can control two 162 fueling positions.

For sites with ~~five to twelve 162 fueling positions~~, a TMS MPC-162 Pump Card IC Box (holds up to four pump cards) is required in addition to the system described above.

A site with ~~thirteen to sixteen 162 fueling positions~~ requires a second Pump Card IC Box (three IC boxes in all), that holds the remaining MPC-TM96 pump cards (up to two).

The standard cable (from console to interconnect box) furnished with the MPC console system is 25 feet long. Optional cable lengths of 50, 75, 100, and 150 feet are available, and can be used in place of the standard length cable.

MPC consoles can control MPDs with a maximum of 4 grades per side. The maximum number of fueling positions permissible per MPC system is 8 for an MPC-8, or 16 for an MPC-16, where each side of an MPD (no matter how many grades) counts as one fueling position.

To control a combination of Tokheim 162, 262A, and TCS, TCSA, or Premier B, EB, B3 Blend style pumps/dispensers, **OPTIONAL** MPC-TM93 pump card(s) (2 max.) must be plugged into the MPC-TM97 communication board in the main TMS MPC-162 IC Box as shown in Fig. 2. Each MPC-TM93 allows up to four sets of data wire connections (communicates with four pumps/dispensers).

To control mechanical as well as electronic pumps/dispensers, the MPC console must be ordered configured as a **HYBRID**. Also required is an 800F mechanical control IC box, a TMS-47 mechanical cable, and one TMS-23 relay board per fueling position.

When ordering a system, list the number and the style of dispensers being controlled, and TMS will ship the required components.

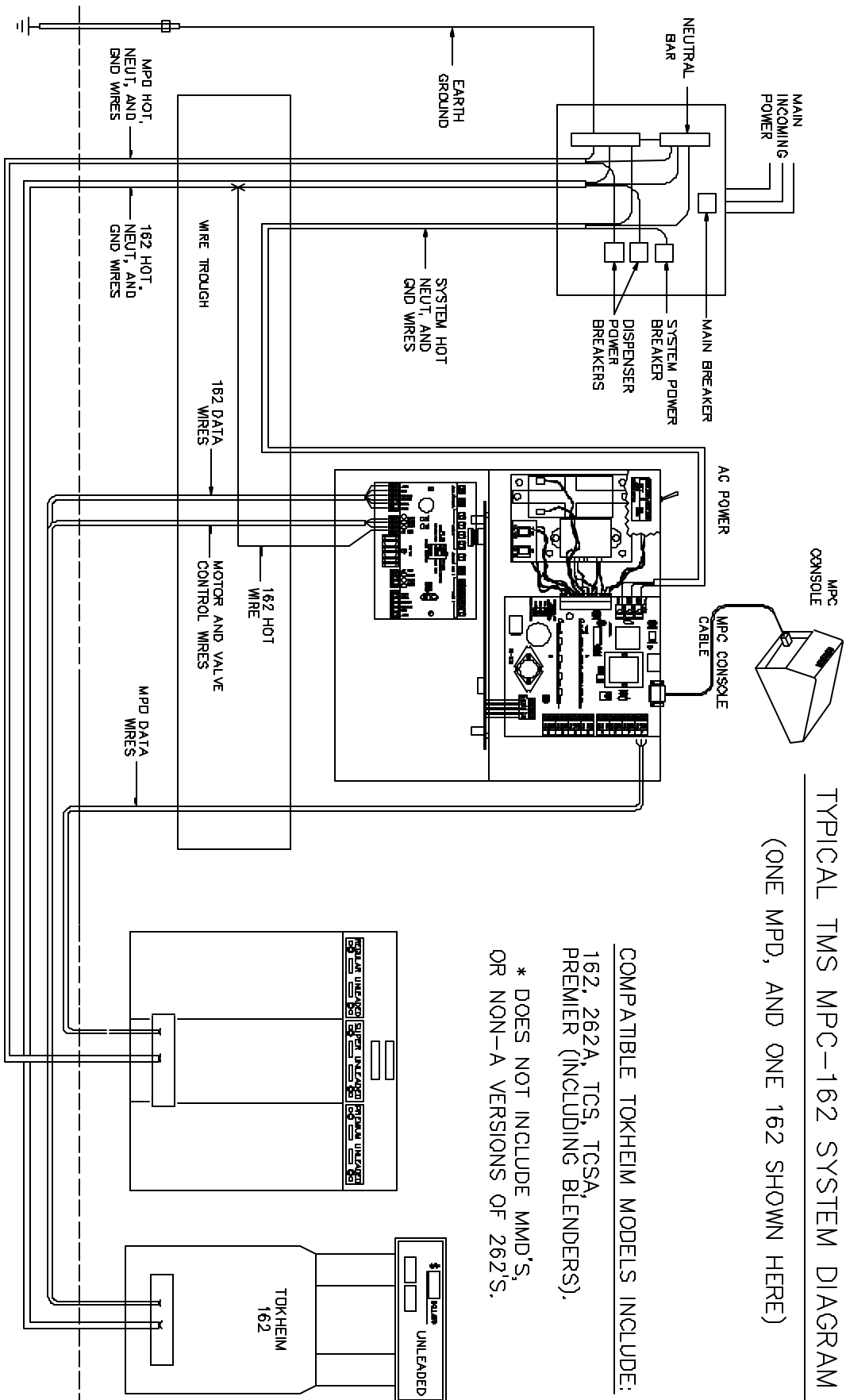

TYPICAL TMS MPC-162 SYSTEM DIAGRAM

(ONE MPD, AND ONE 162 SHOWN HERE)

COMPATIBLE TOKHEIM MODELS INCLUDE:
 162, 262A, TCS, TCSA,
 PREMIER (INCLUDING BLENDERS).

* DOES NOT INCLUDE MMD'S,
 OR NON-A VERSIONS OF 262'S.

Figure 1 Typical TMS MPC-162 System Diagram

SYSTEM POWER REQUIREMENTS:

MPC Console Power Input.....Dedicated 115VAC, .5 Amp Max. 50/60 Hz.
AC Emergency OFF Contact.....115 VAC 1 AMP Max., 120 Watt Max.

ENVIRONMENTAL REQUIREMENTS:

32 F to 104 F (0 C to 40 C), Non-condensing humidity.
Avoid exposure to direct sunlight or heat. Locate the console in an area that allows an unobstructed view of all fueling positions.

CONSOLE TO INTERCONNECT BOX CONNECTION:

Connection between the MPC Console and the MPC Interconnect Box is made through a 25 foot round cable having 15 conductors and 2 "D" type connectors. Longer optional cables are available through your dealer. The maximum recommended distance between the MPC Console and the MPC Interconnect Box is 150 feet.

Connection between the MPC ~~HYBRID~~ Console and the **OPTIONAL MECHANICAL** 800F IC Box is made through a 25 foot round cable with 44 conductors ,1 "card edge" connector, and 8 slide on "Molex" connectors. The maximum recommended distance between the MPC ~~HYBRID~~ Console and the 800F Interconnect Box is 150 feet.

DIMENSIONS:

MPC Console.....7-3/8" W x 5-1/4" H x 8-3/4" D
TMS MPC-162 IC Box.....17-1/4" W x 14-1/4" H x 4" D
Optional Mechanical Dispenser Control Equipment:
(Hybrid console required)
800F IC Box.....13-3/4" W x 4" D X 15" H

WEIGHT:

MPC Console.....6 lbs.
TMS MPC-162 Main IC Box.....19 lbs.
TMS MPC-162 Pump Card Box.....13 lbs.
MPC-TM96 Pump Card.....1/2 lbs.
MPC Cable (25 ft.).....2 lbs.
Optional Mechanical Dispenser Control Equipment:
(Hybrid console required)
HYBRID MPC Console.....8 lbs.
800F IC Box.....16 lbs. plus 1/2 lbs. per fueling position.

NOTE: The above weights do not include shipping cartons or packing materials.

PERIPHERAL INTERFACE INSTALLATION:

In compliance with the UL regulations and standards that apply to the Petroleum Industry, the following information establishes installation parameters for the use of peripheral equipment with the TMS MPC Control Console.

1. Any peripheral equipment must be UL listed.
2. Any peripheral equipment must have an Electronics Industry Association (EIA) Standard RS-232C or RS-422A communications interface (whichever is appropriate for the application).
3. Any peripheral equipment must not be installed in or above a hazardous location.
4. The peripheral interconnection cable must be either UL Style 1061 or 2462 suitable for interconnection of electronic equipment.

TMS MPC-162 MAIN INTERCONNECT BOX DESCRIPTION

The main TMS MPC-162 Interconnect Box includes, on the outside, a TOGGLE SWITCH, and on the inside, a MPC-TM97 communication board, a MPC-TM98 distribution board, a MPC-TM99 power supply, and can hold two MPC-96 pump cards, and two MPC-TM93 pump cards.

MPC-TM96: These pump cards are the "brains" for the Tokheim 162 dispensers. They receive handle and pulse signals from the 162 dispensers, control the 162 valves and pump motor, and send the data that shows the sale amounts at the pump and on the console.

MPC-TM97: This communication board/power supply receives the incoming line voltage, supplies the system with AC and DC voltage, transmits data signals between the console and the MPC-TM96 boards, allows the connection of "smart" pumps/dispensers (if optional MPC-TM93 boards are installed), and has a relay that is de-activated by pressing the Emergency Off button or turning the OFF/ON key switch to the OFF position (see number fourteen of the "Important Notes" section for the Emergency Off description).

MPC-TM98: This distribution board allows connection of the MPC-TM96 pump cards and TMS MPC-162 Pump Card Boxes to the main IC box, and carries data signals from the MPC-TM97 to all MPC-TM96's.

MPC-TM99: This power supply contains a transformer, a 12vdc battery, and circuit breakers for the AC input voltage (1/2-amp) and the 12vdc output voltage (2-amp).

NOTE: In the event of power failure, or whenever AC power to the system is turned off, the 12vdc battery must be disconnected to prevent unnecessary power drain. There are two methods of disconnecting the battery:

1. If the MPC console is connected, turning the OFF/ON key switch to the OFF position automatically disconnects the battery.
2. In STAND ALONE (no console) operation, the TOGGLE SWITCH on the outside of the Main IC Box disconnects the battery circuit. Turn the switch to the "**STAND ALONE OFF**" / "**CONSOLE CONTROL**" position whenever AC power is turned off, or in the event of power failure (after all sales have been completed). Refer to Fig 2 on page five.

TOGGLE SWITCH: Located on the outside of the main MPC-162 IC box, this switch disconnects the battery circuit when a MPC console has been disconnected. Normally, this switch should be turned to the "**STAND ALONE OFF**" or "**CONSOLE CONTROL**" position. When operating without a console, the switch should be turned to "**STAND ALONE**" to supply +12vdc to the displays in the event of power failure.

REMEMBER: While running in stand alone, turn the TOGGLE SWITCH to the "**STAND ALONE OFF**" or "**CONSOLE CONTROL**" position if power is removed from the system (after all sales have been completed).

MPC-TM93: These **OPTIONAL** pump cards control Tokheim 262A, TCS, TCSA, and Premier (up to four grades per fueling position), including blend style, pumps/dispensers. MPC-TM93 pump cards (2 max.) are plugged into the MPC-TM97 communication board in the sockets provided as shown in Fig. 2. Each MPC-TM93 allows connections of up to four pumps/dispensers.

TMS MPC-162 PUMP CARD BOX DESCRIPTION

The TMS MPC-162 Pump Card Box includes a MPC-TM98 distribution board, and can hold four MPC-96 pump cards.

FOR THE SAFE INSTALLATION, MAINTENANCE, AND OPERATION OF THIS CONSOLE AND RELATED EQUIPMENT, READ AND UNDERSTAND ALL WARNINGS AND CAUTIONS.

"DANGER" means: If you do not follow the instructions, severe injury or death **WILL** occur.

"WARNING" means: If you do not follow the instructions, severe injury or death **CAN** occur.

"CAUTION" means: If you do not follow the instructions, damage can occur to the equipment.

DANGER: Disconnect all power to this equipment and associated submerged pump(s) during installation, service or any maintenance. Failure to do so can cause injury or damage equipment.

WARNING: Maintenance and repairs must be done by **QUALIFIED/TRAINED** personnel only.

WARNING: To prevent electric shock, keep the electrical parts of the console dry.

WARNING: You must have training in the installation and service of fuel dispensing equipment before working on this system.

WARNING: Make sure this equipment is correctly grounded. Failure to do so can cause injury or damage equipment.

CAUTION: Electronic components are static sensitive. Use proper static precautions (static straps) before working on the equipment.

WARNING: Failure to properly ground all equipment can cause injury or damage equipment.

WARNING: Installation must comply with National Code (NFPA #70), Automotive and Marine Service Code (NFPA #30A), Federal, State and local codes.

CAUTION: This equipment generates and uses radio frequency energy. If not installed and used properly, i.e., in strict accordance with the instructions in this manual, it may cause interference to radio communications. The console was tested and found to comply with the limits for a Class A computing device in accordance with Sub-part J of Part 15 of the FCC Rules. A Class A computing device is designed to provide reasonable protection against interference when operated in commercial environment.

CAUTION: Follow proper grounding procedures to reduce radio frequency interference (RFI). Ground each piece of equipment connected to, or controlled by, the console to the electrical service panel ground.

CAUTION: Each dispenser must have a 12 gauge or larger green stranded ground wire connected from the grounding lug of the junction box to the main electrical service panel ground. (National Electrical Code, Article 514-7). It is unacceptable to rely on the conduit for this grounding requirement.

CONNECTION INSTRUCTIONS FOR THE SYSTEM POWER SUPPLY, DISPENSER, MOTOR, AND ELECTRICAL GROUND CIRCUITS.

A.C. POWER REQUIREMENTS

- 1. Breaker Panel:** A 125 Amp breaker panel is the minimum allowable electrical service for the pump motor, console, dispensers, canopy lights and advertising signs.
- 2. Main IC Box:** The main Interconnect Box requires a 115VAC, 15 Amp **DEDICATED** breaker (with no other devices or outlets connected to it) for connection to the MPC-TM97 board. Make sure the correct voltage and frequency are present. All AC wires must be 14 gauge, and in conduit. Do not put wiring from other sources in this conduit.
- 3. Pump Card Box:** Secondary pump card boxes do not require an AC connection. Only the MPC-TM96 pump cards inside the Pump Card Box require an AC connection. See figures 6 and 7, on pages 12 and 13, for wire diagrams of MPC-TM96 pump cards and 162 pumps/dispensers.
- 4. 162 Dispensers:** These dispensers require a 115VAC breaker. Use THHN stranded wires for the data signals, solenoid valves, power supply and dispenser fluorescent lighting, and a green stranded wire for Earth Ground. Refer to the installation manual for the dispenser being installed for complete installation requirements.
- 5. "Smart" Dispensers:** The dispensers' installation guide shows all requirements including, but not limited to breakers, wires to supply data signals to the electronics, green wire for ground, and wires to power the dispenser and fluorescent lighting. Refer to the installation manual for the dispenser being installed for complete installation requirements.
- 6. TMS 800F IC Box:** The IC Box requires a 115VAC, 15 Amp **DEDICATED** breaker (it can share the same breaker used for the TMS MPC-TOKHEIM IC Box) for connection to the TMS-78 power supply board. Make sure the correct voltage and frequency are present. All AC wires must be 14 gauge (min.), and in conduit. Do not put wiring from other sources in this conduit.
- 7. Mechanical Dispensers:** The dispensers' installation guide shows all requirements including, but not limited to breakers, green wire for ground, and wires to power the dispenser and fluorescent lighting. Refer to the installation manual for the dispenser being installed for complete installation requirements.
- 8. Pump Motor:** Use auxiliary contactors, 14 gauge wires (min.), and 115/230VAC breakers to supply power to the pump motors. Refer to the installation manual of the equipment being used for complete installation requirements, drawings, and special notes for proper installation.

TO INSTALL THE MPC CONTROL SYSTEM, FOLLOW THIS PROCEDURE:

1. Mount all interconnect boxes near the wire trough, or where the conduit from the pumps enter the building.
2. Connect the Tokheim 162 data signal and valve wires from each fueling position to the MPC-TM96 pump card(s) terminal strips in the TMS MPC-162 Interconnect Boxes. Refer to specific wire diagrams on page 11, figure 6 for dispensers and page 12, figure 7 for pumps.
3. Connect any "smart" pump/dispenser data wires to the MPC-TM97 communication board terminal strips in the main Universal interconnect box as shown in fig. 2, on page 5.
4. Connect any mechanical pump/dispenser control wires as shown in the TMS-800F Installation Guide.
5. Place the console in a location that allows an unobstructed view of all fueling positions at the site.
6. Using the screws provided, connect the data cable(s) from the console to the interconnect box(es).

CONNECTING MECHANICAL CABLES TO HYBRID CONSOLES

HYBRID MPC CONSOLE WITH ONE MECHANICAL INTERFACE (IF) BOARD

An eight fueling position hybrid MPC console contains one mechanical IF Board and allows addressing of mechanical (and electronic if applicable) pumps/dispensers to any fueling position (1-8).

A sixteen fueling position hybrid MPC console that contains only one mechanical IF Board limits addressing of mechanical pumps/dispensers to fueling positions nine through sixteen (9-16).

Refer to figure Q to connect a TMS-47 mechanical cable to a hybrid MPC console with one mechanical IF Board.

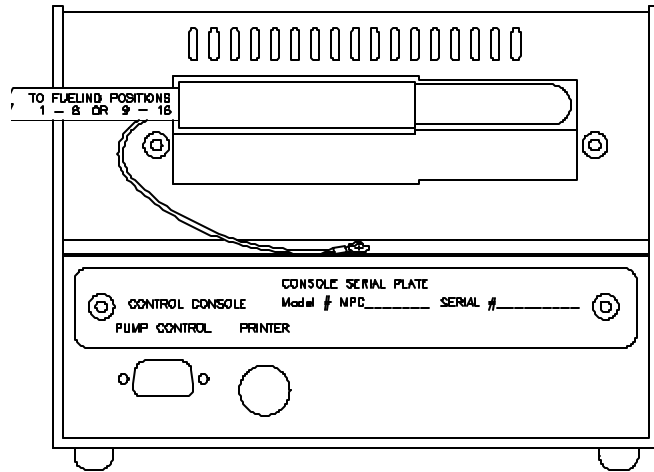

Figure 3 Hybrid console with one mechanical IF board

HYBRID MPC CONSOLE WITH TWO MECHANICAL INTERFACE BOARDS:

A sixteen fueling position hybrid MPC console with two mechanical IF Boards allows addressing of mechanical pumps/dispensers to one through sixteen (1-16), providing two TM-47 mechanical cables and 800F IC Boxes are present.

Refer to figure Z to connect TMS-47 mechanical cables to a hybrid MPC console with two mechanical IF Boards.

NOTE:

Select the correct cable connector for the desired mechanical fueling position number. The cable connector marked as "1" is the first available position, and "8" is the last. For sites with mechanical pumps/dispensers addressed as fueling positions nine through sixteen, cable connector "1" corresponds to fueling position nine (9), and "8" corresponds to position sixteen (16).

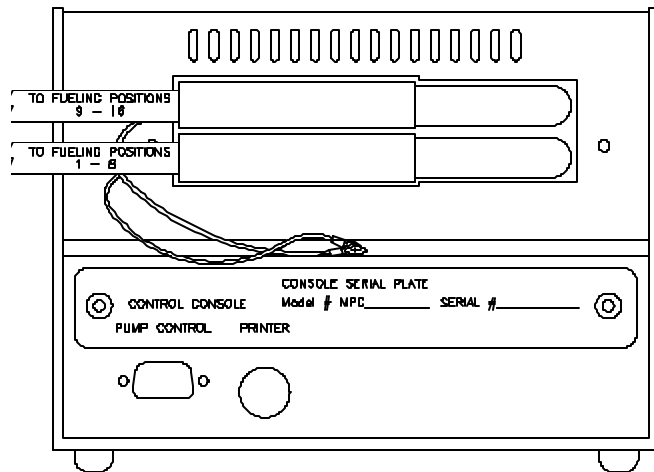

Figure 4 Hybrid console with two mechanical IF boards

HOW TO INSTALL OR REPLACE INDIVIDUAL MPC-TM96 PUMP CARDS

Each MPC-TM96 pump card is held in place with two screws on the outside edge and the pin connector on the inside edge. Exercise care when replacing MPC-TM96 pump cards to prevent damage to the connector and or pins.

HOW TO CONNECT TMS MPC-162 INTERCONNECT BOXES TOGETHER

Use five 22 gauge or larger wires when making connections between the Main MPC-162 IC Box and the MPC-162 Pump Card Boxes. Make connections as shown in figure 3, with +12V to +12V, GND to GND, etc...

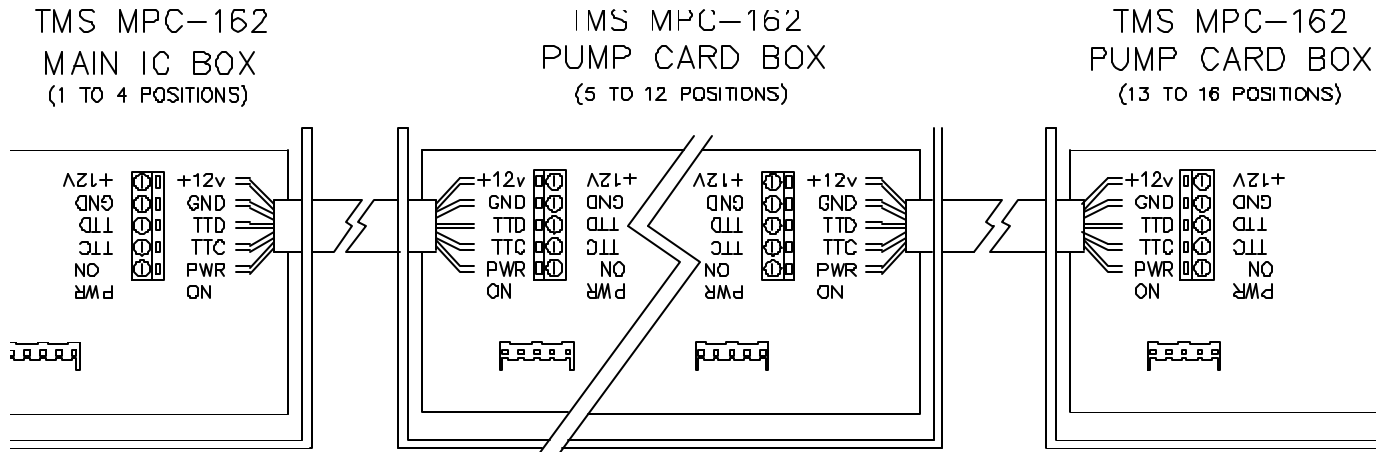

Figure 5 TMS MPC-162 IC Box Connection Diagram

PROGRAMMING THE MPC-TM96 PUMP CARD

Each MPC-TM96 pump card can control two fueling positions, and each fueling position on the pump card is designated as either A or B (for programming purposes only). Figure 4 shows a description of the programming switches. For correct operation, each fueling position must be setup on a pump card as follows:

"ADDR" (Address) - There are sixteen available fueling positions, 0 thru 9, and A thru F. Use the rotary switch labeled ADDR, and the following chart to assign a fueling position number to each 162 pump/dispenser.

162 fueling position #	rotary switch position	162 fueling position #	rotary switch position
1.....	0	9.....	8
2.....	1	10.....	9
3.....	2	11.....	A
4.....	3	12.....	B
5.....	4	13.....	C
6.....	5	14.....	D
7.....	6	15.....	E
8.....	7	16.....	F

"PROG" (Program) - Select the desired operation for each fueling position in use by setting the four position dip-switch.

NOTE: LEAK TEST delays activation of the valves for three seconds to allow connection of leak detectors.

With a fueling position connected, and being controlled by the MPC console, the dip switch should be set as follows:

- 1 = ON (ON LINE)
- 2 = ON (CONSOLE CONTROL)
- 3 = ON or OFF (LEAK TEST - optional)
- 4 = not used

With a fueling position connected, but running in STAND ALONE, the dip switch should be set as follows:

- 1 = ON (ON LINE)
- 2 = OFF (STAND ALONE)
- 3 = ON or OFF (LEAK TEST -optional)
- 4 = not used

NOTE: WHEN RUNNING IN STAND ALONE, THE PRICE IS SET AT THE MPC-TM96 PUMP CARD USING THE PRICE ROTARY SWITCHES.

When a fueling position is not connected, the dip switch should be set as follows:

- 1 = OFF (OFF LINE)
- 2 = OFF (STAND ALONE)
- 3 = OFF (NO LEAK TEST)
- 4 = not used

"PRICE" (Price) - The price per gallon must be set at the MPC-TM96 pump card ~~only~~ if STAND ALONE operation has been selected on the four position dip switch. Refer to figure 4 on page 10 and use the rotary switches labeled PRICE to program the price per gallon for each fueling position in STAND ALONE operation.

HOSE A (1-16)

AM SWITCH HOSE A

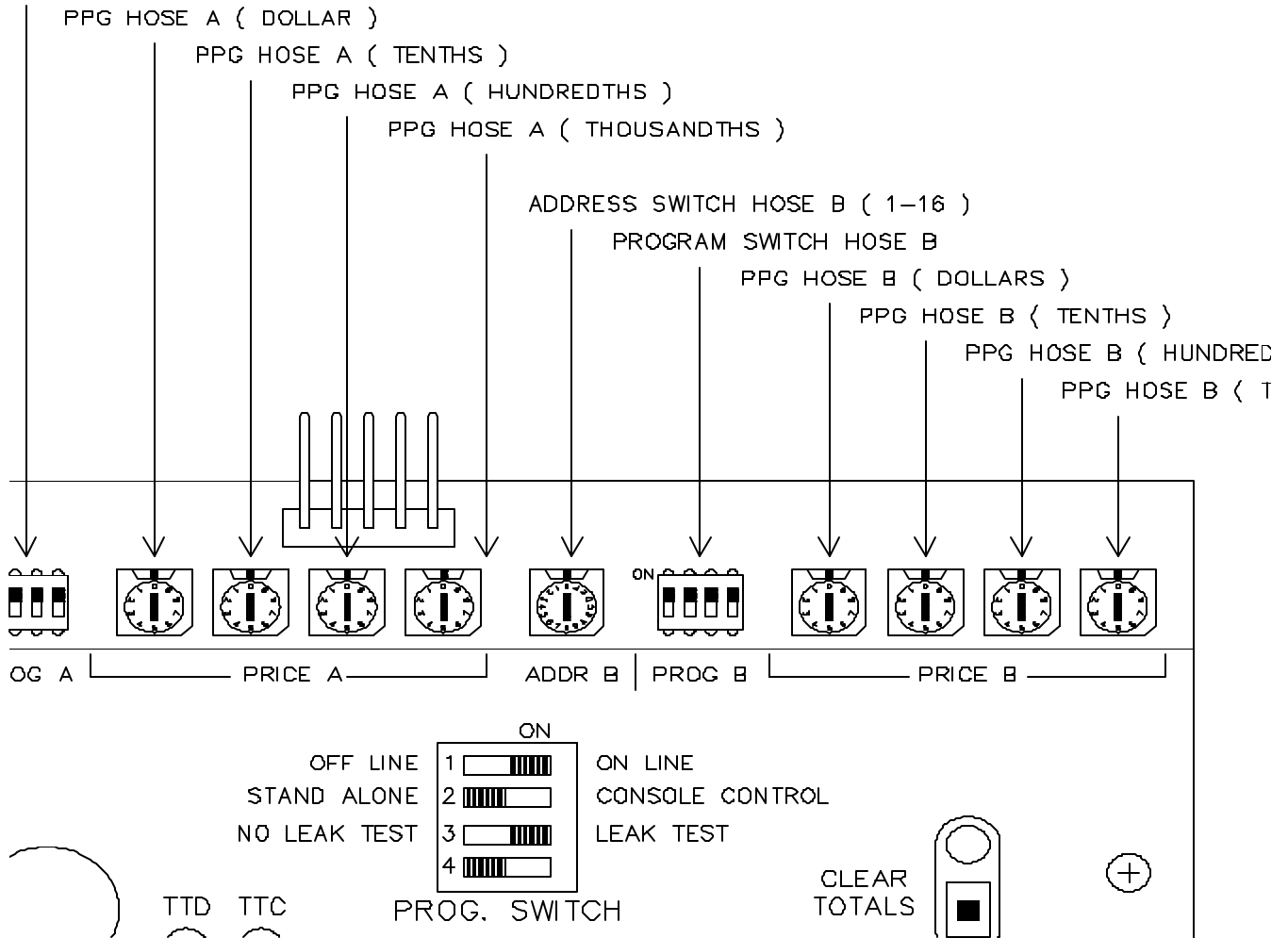

Figure 6 MPC-TM96 Pump Card Switch Description

IMPORTANT NOTES:

1. All +12vdc, GND, HANDLE, PULSER, DATA, and SYNC wires connections between the MPC-TM96 pump cards and the dispensers must be 18 gauge or larger.
2. All AC wires including MOTOR, SLOW, FAST, and AC HOT must be 14 gauge or larger.
3. Use cable ties to keep the data cable in place from the console to the interconnect box if conduit is not used.
4. If the MPC cable is put through a conduit, use 2" minimum to allow room for the connectors on the cable. Do not cut connectors from the MPC cable to use smaller conduit. Do not put MPC cable conduit underground. MPC data cables are not designed to operate under these conditions and will not be covered under warranty.
5. Do not use wire nuts on any grounding connections. Make all connections with compression connectors (crimp or split lug).
6. If the console or dispenser power comes from a sub-panel, all ground wires must end at the main electrical service panel ground.
7. There must be no more than 1 ohm resistance between Neutral and Earth Ground.
8. Do not use old or used wire for dispenser wire connections.
9. Use rigid metal conduit only. Do not use PVC conduit.
10. Do not route mercury vapor, canopy light wiring, or other unrelated wiring through the dispenser wiring conduit.
11. Auxiliary relays or contactors MUST BE used in the motor circuit! Refer to the installation manual of the dispenser for complete installation requirements, drawings, and special notes.
12. Wiring for dispensers, TMS MPC-162 IC box, and other control boxes should all be on the same phase from the service panel, or erratic operation/communication could result.
13. In the interest of everyone's safety, all persons involved in the operation of this system should be made aware of a proper power-down sequence for all components used to dispense flammable products.
14. The EMERGENCY OFF connector supplies a dry contact relay closure across COM. and N.O. while console is on and not in "EMER OFF" condition. While console is turned OFF via the OFF/ON key, and/or during the time the "EMER OFF" button has been pressed so that the "EMER OFF" light is flashing, the connector supplies an open circuit across COM and N.O. Figure 5 shows the Emergency Off connector located in the main TMS MPC-162 IC Box.

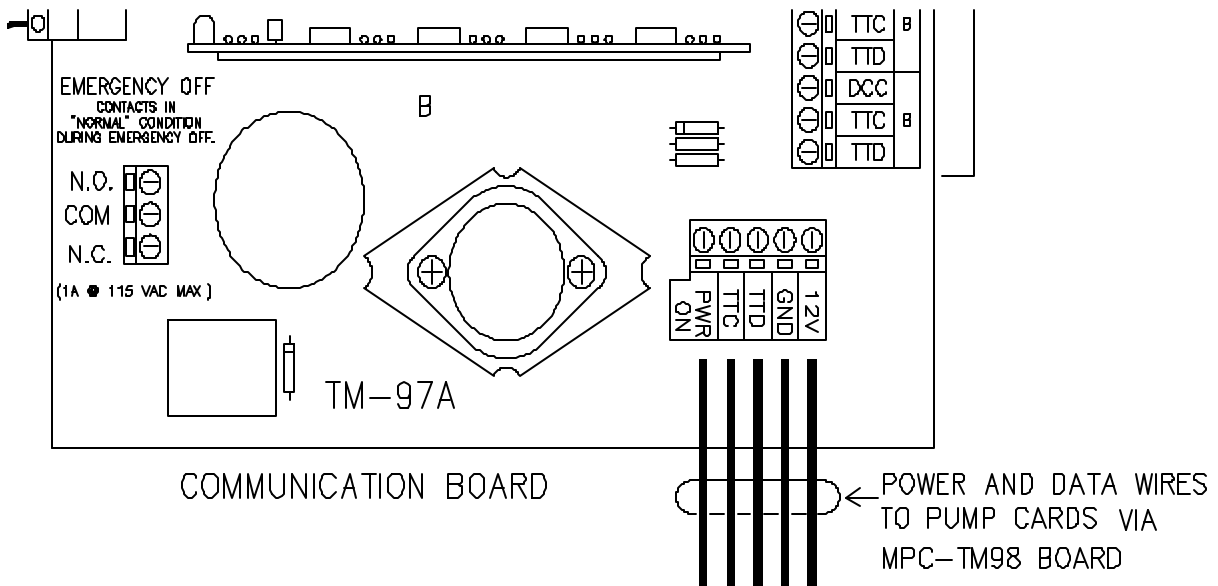

Figure 7 Emergency Off Connector Located in Main TMS MPC-162 IC Box

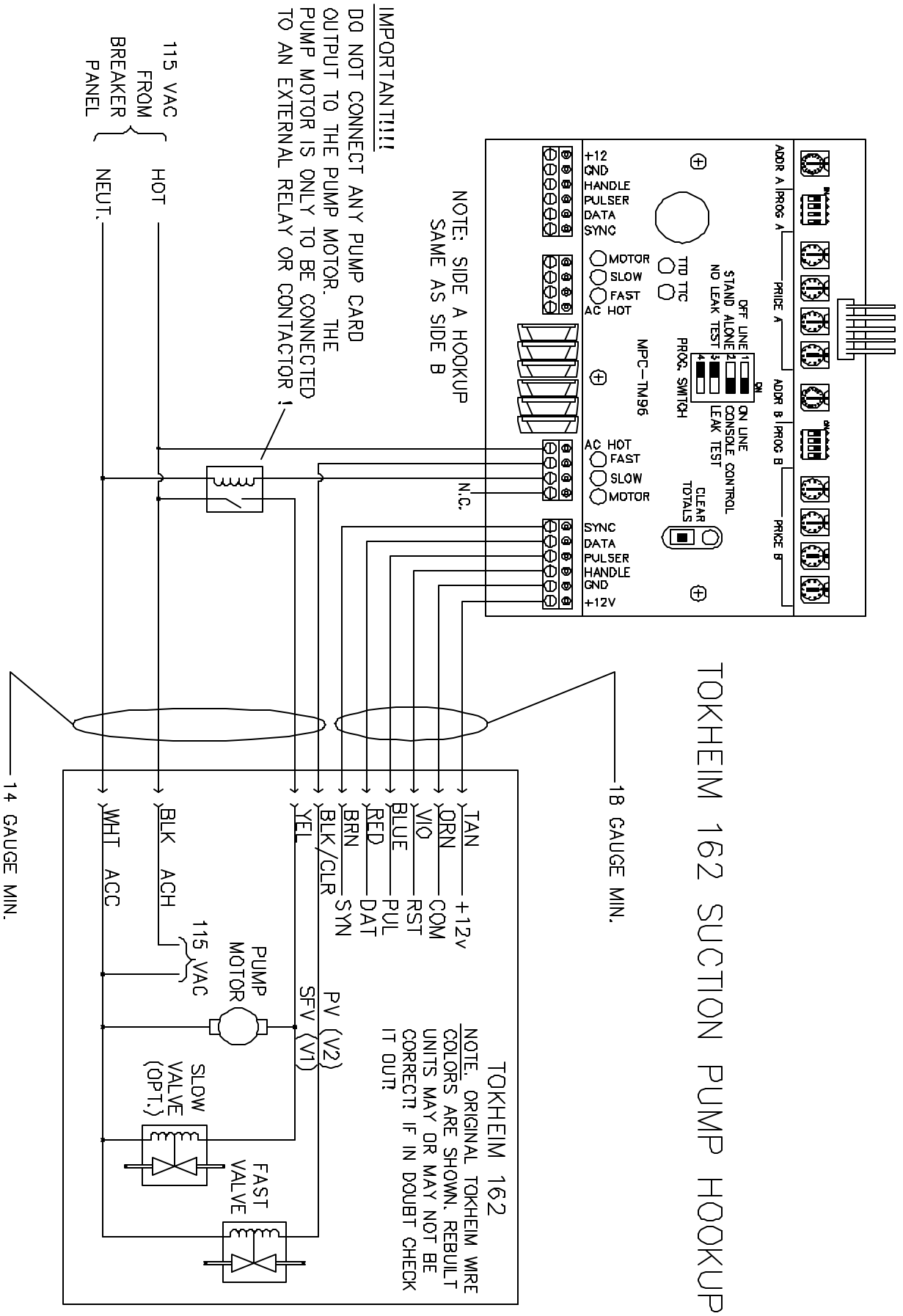

Figure 9 162 Suction Wiring Diagram

START-UP PROCEDURE:

1. Confirm all equipment has been properly installed and grounded.
2. Apply power to the pump/dispensers after Consulting the installation guide for the equipment being installed.
3. Set the "smart" pumps/dispensers so that:
 - a. The communication is set for VISION, MEMS IV, MEMS V, and the 83 DHC.
 - b. Slow flow setting set at pump (F18).
 - c. MODE F19 is set to console control.
 - d. MODE F23 is set with the desired address and pricing structure.

NOTE: If a problem exists with the pumps/dispensers, contact the equipment distributor, or the manufacturer's customer service department.

4. The TMS MPC Console CAN send the blend ratio to the pump/dispenser. **Set the premier blender pump/dispenser's MODE F26 at 1 so it will accept the console's blend ratio.**

REMEMBER: This is only a suggestion and does not limit the programming required for TOKHEIM pumps/dispensers to operate correctly.

5. Apply power to the MPC system.
6. Turn the MPC console OFF/ON key switch to the on (horizontal) position.
7. Use the **PROGRAMMING INSTRUCTIONS FOR MPC CONTROLLERS** to program the console.

NOTE: P P P P P . P P in the display window after the key has been turned on, indicates a power problem. Confirm all connections are correct, and that the breaker is switched to the on position. If problem persists, contact the equipment distributor, or the fuel control service department at Triangle Microsystems (TMS), Raleigh, NC. at 1-800-334-5548.

TURNING THE SYSTEM OFF:

It is not recommended or necessary to turn OFF the dedicated system breaker that supplies power to the MPC-TM97 board during the time the store/station is closed. Simply turning the console OFF/ON key to the OFF position after all hoses have been de-authorized, along with following the dispenser power down sequence, will prevent fuel from being dispensed.

IN CASE OF EMERGENCY:

In an emergency situation that requires one or more pump/dispensers to be turned OFF, push the "EMER OFF" button on the front of the MPC Console ("EMER OFF" light blinks). This causes two things to happen:

1. A "turn OFF" signal is sent to every pump/dispenser.
2. The EMERGENCY OFF relay on the MPC-TM92 board is deactivated (goes to "normal" condition).

To return to normal operation, push the "EMER OFF" button again ("EMER OFF" light goes out). Two things will happen:

1. A "Resume pumping" signal will be sent to each pump that was originally pumping (and not yet hung up).
2. The EMERGENCY OFF relay will be activated.

TMS SERVICE AND WARRANTY INFORMATION

The TMS MPC systems are designed to be serviced by unit substitution.

The substitution units for MPC electronic systems are: CONSOLE, CABLE, and all INTERCONNECT BOARDS.

The substitution units for MPC mechanical/hybrid systems are: ALL OF THE ITEMS LISTED ABOVE, and TMS-23 Relay Board, TMS-47 Cable, and TMS-78 Power Supply Board.

Service vehicles **are expected** to carry parts for installation and service work TO ELIMINATE THE NEED FOR RETURN TRIPS TO INSTALL REPLACEMENT PARTS.

All components manufactured by TMS have a one year FACTORY SERVICE WARRANTY plus a 12 month grace period for distributors to cover shelf time or exchanges with their customers for repairs (this warranty does not apply to printers, pulser/totalizers, or time delay relays, which are not manufactured by TMS; these components are warranted for 90 days). The warranty starts from the date of shipment from TMS.

During the factory service warranty period, these units may be returned to Triangle MicroSystems, Inc., freight prepaid. They will be repaired and returned freight prepaid, at no charge.

Exceptions to free factory warranty service are:

Lightning damage

Obvious physical damage

Damage due to connecting/mis-connecting "HOT" (115 VAC) wires to the +12v, GND, HANDLE, PULSER, DATA, SYNC signal inputs.

Damage due to connecting/mis-connecting grounded or neutral wires to MOTOR, SLOW, FAST, or AC HOT connections.

Damage due to connecting/mis-connecting "HOT" (115 VAC) wires to the TTC, TTD, DCC data signal inputs.

Damage due to connecting/mis-connecting line voltage other than specified in this book to AC INPUT connections.

Damage due to connecting/mis-connecting line voltage or loads rated other than specified at the EMERGENCY OFF terminal of the MPC-TM97 IC board.

The TMS FACTORY SERVICE WARRANTY **DOES NOT COVER TRAVEL AND LABOR CHARGES**. Our service policy is to repair and return, or exchange for re-manufactured components. We ~~do not~~ send out new parts and take back old ones at no charge.

To help reduce service costs, TMS is willing to drop-ship parts, at your request, anywhere that UPS delivers.

Due to an increased demand for advance warranty exchanges, there will be a minimum charge of \$25.00 to cover the cost of a new overlay and cleaning of dirty console cases. Serial numbers with date codes are required when ordering exchange units.

If you wish to exchange a TMS console with a partially expired warranty for a remanufactured, fully re-warranted unit, you can do so and pay only for the portion of warranty used. See the last page of our price book for pricing information.

TRIANGLE MICROSYSTEMS, INC.
WARRANTY AND LIMITATIONS OF REMEDIES

1. Seller warrants that the equipment shall be free of defective parts and workmanship for a period of two (2) years commencing on the day of the invoice from Seller. Sellers salesman, distributors, representatives or agents may have made oral statements about the equipment described herein. Such statements do not constitute warranties, shall not be relied on by the buyer and are not part of this contract of sale. **EXCEPT AS SET FORTH ABOVE, SELLER MAKES NO WARRANTY, EXPRESS OR IMPLIED, TO BUYER OR ANY OTHER PERSON AS TO THE EQUIPMENT'S FITNESS FOR A PARTICULAR PURPOSE, MERCHANTABILITY, DESIGN, CONDITION OR ANY OTHER ASPECT OF THE EQUIPMENT WHICH IS THE SUBJECT OF THIS CONTRACT OF SALE, ITS COMPONENTS, WORKMANSHIP AND MATERIALS, BUYER TAKES AND ACCEPTS THE EQUIPMENT AS IS.** By reason of his acceptance of delivery of the equipment, Buyer agrees that the equipment is in proper operating order, conforms to the Buyers specifications and the terms and conditions of the contract of sale, and has accepted the equipment in its condition on delivery as the equipment described herein.
2. Buyer's remedies for damages due to breach of the warranty set forth herein shall be limited to repair or replacement of non-conforming goods or parts within the aforesaid time period of two (2) years. **LABOR, TRANSPORTATION, AND TRAVEL ARE NOT COVERED BY THE WARRANTY.** The parties agree that the Buyer's sole and exclusive remedy against the Seller shall be for the repair or replacement of defective parts or goods as provided herein. Buyer agrees that no other remedy, including but not limited to incidental or consequential damages for lost profits, lost sales, injury to persons or property, or any other incidental or consequential loss, shall be available to it. Seller further disclaims liability for any loss, damage or injury to any person as a result of any defects, latent or otherwise, in the equipment whether arising from Sellers negligence, application of the law of strict liability, or breach of warranty.
3. This warranty is automatically void and of no effect in the event of defect, damage, injury or failure of the equipment due to any of the following causes: Acts of God; improper installation; failure to maintain the equipment in accordance with the Seller's instructions; use of the equipment in any manner other than the use for which the Seller has designed and intended the equipment; attempt to install, repair or replace the equipment by any person other than Seller's authorized employees or agents; modifications or changes to the equipment of any kind or nature; excessive or improper usage and electrical burnouts or surges.
4. This writing contains the final expression of the parties' warranty agreement and is a complete and exclusive statement of the terms of the agreement. Parol evidence shall not be admissible to supplement, modify or add to the terms hereof for any purpose.