

Basyx IPR

Communications Repeater

Installation & Setup Manual

IPR-ISM Revision 1.1
05/29/2008

BASYX IPR

Communications Repeater

Table of Contents

Overview	3
Module Details	3
Connection Details	4
Power Connection	4
RS485 Communications Connection (Main Loop)	5
RS485 Communications Connection (Channel Loop)	6
Program Switch Operation	7
RS485 / RS232 Jumper Settings	8
Typical System Configuration	9
Loop Extender Configuration	9
Channel Configuration	9
Branch Configuration	11
About the BASYX Product Line	12

Warning (For your Safety)

All electrical connections must be in agreement with local codes, ordinances or the National Electric Code (NEC).

Do not install in areas that experience high levels of electrical interference, moisture or exposure to water.

OVERVIEW

This manual describes the proper procedure for installation and connection of the **BASYX IPR** repeater module. This device provides extension of the standard RS485 communications bus beyond the 4000' limit, as well as allowing channels to be implemented for routing to different areas within a facility. The IPR Module is a transparent pass-thru device and requires no software, programming or addressing. The **BASYX IPR** additionally provides protection through optical isolation and fused communications inputs and outputs. Please follow these instructions carefully to insure proper operation of the IPR communications module.

MODULE DETAILS

Figure 1 shows the layout of the BASYX IPR repeater module.

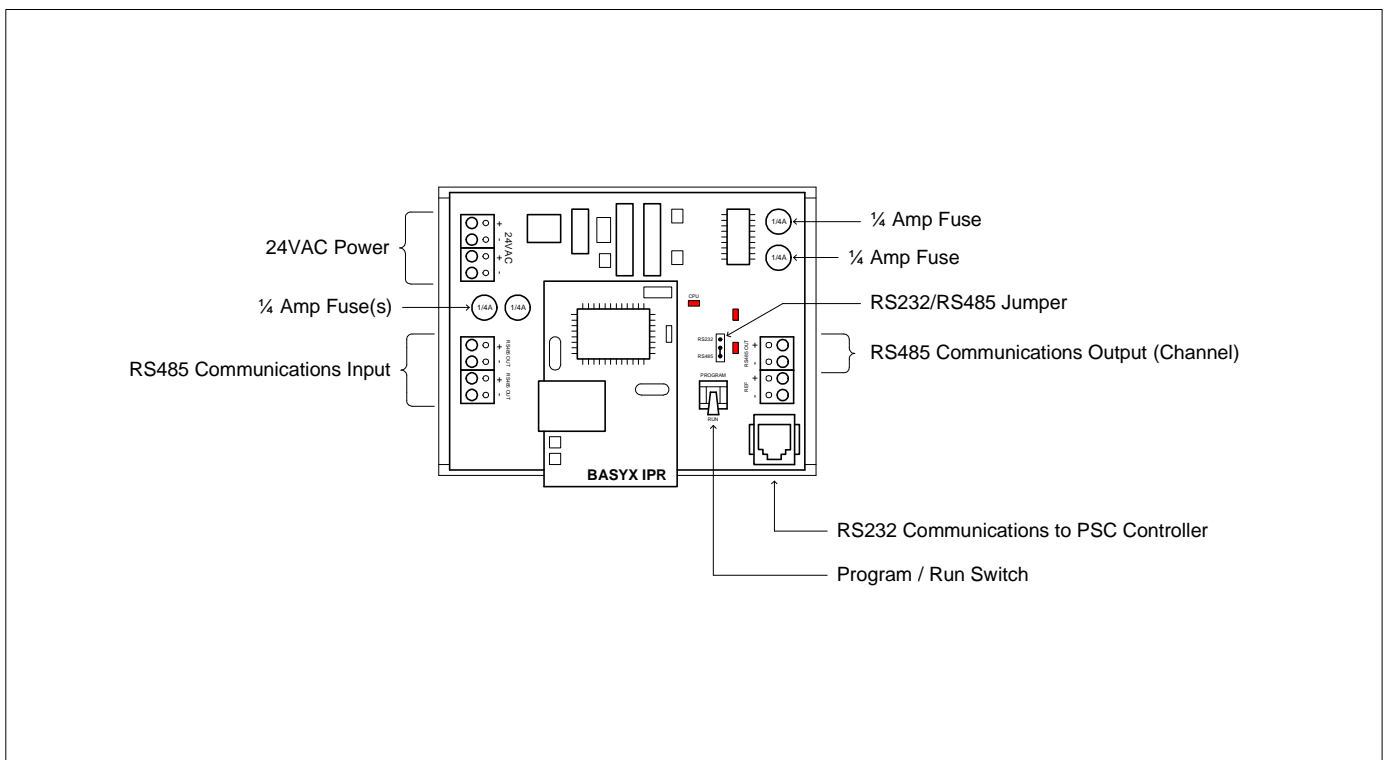

Figure 1: BASYX IPR Repeater Module Details

RJ11 SERIAL PORT:

This connection is used for factory setup of the BASYX IPR and no field connection is required.

PROGRAM / RUN SWITCH:

This is a 2 position toggle switch used for factory programming only.

RS485/RS232 JUMPER:

This jumper **MUST** be set to the RS485 position (jump bottom 2 pins).

FUSES:

Four (4) 1/4 amp plug-in fuses for RS485 protection.

CONNECTION DETAILS

POWER CONNECTION

The BASYX IPR is powered via a standard 24VAC transformer, with recommended 40vA capacity. The power connection should be made with a 1 pair, 18 gauge cable as shown in **Figure 2** below, or 18 gauge stranded hook-up wire if located in panel.

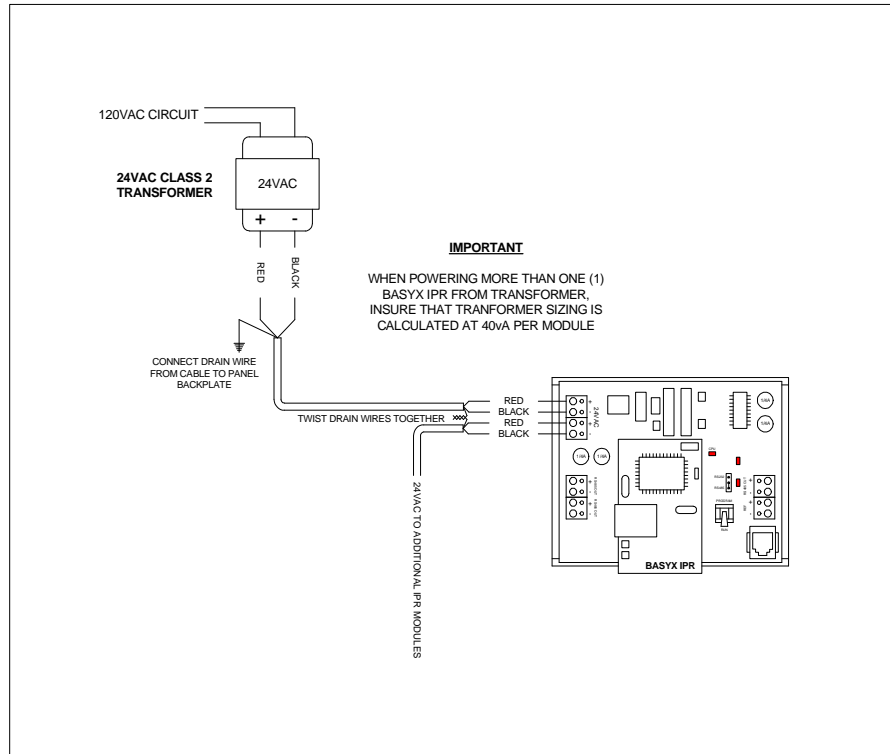

Figure 2: BASYX IPR Power Wiring Details

IMPORTANT NOTE:

When powering multiple IPR repeaters from one transformer, insure that transformer is sized sufficiently to provide the 40vA for each repeater.

If using 2 conductor shielded cable for power wiring, connect drain wire to panel backplate or building ground at the transformer location. Twist drain wires together at each IPR - DO NOT CONNECT TO GROUND OR THE IPR MODULE.

RS485 COMMUNICATIONS CONNECTION (MAIN LOOP)

Multiple repeaters may be installed on the main loop and the BASYX IPR must be connected downstream to at least one (1) PSC controller for proper operation.

Figure 3 shows required 485 connections for main communication loop.

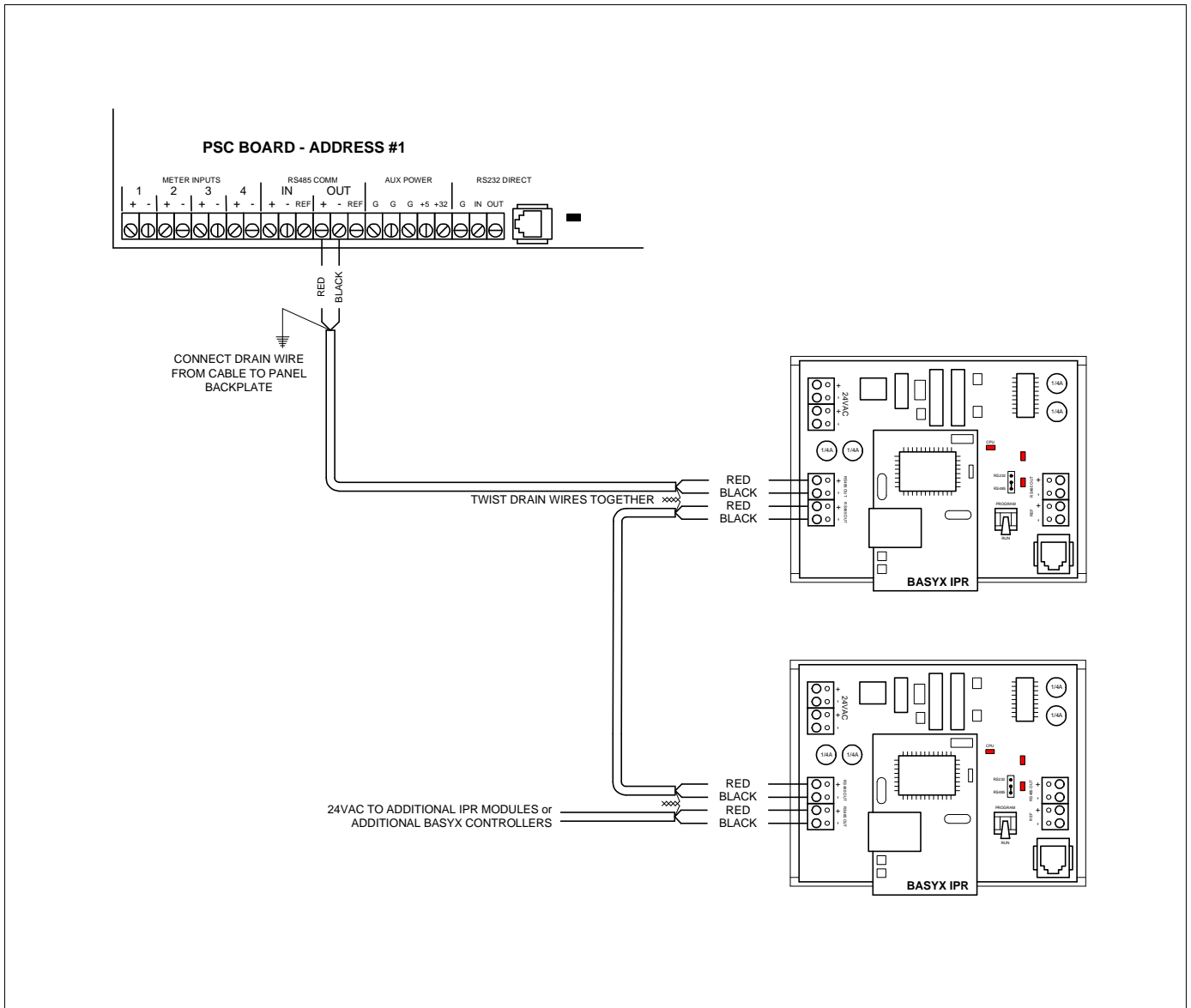

Figure 3: RS485 Main Loop Communications Connection

All communications cable should be 2 conductor, 18-22 gauge shielded, stranded cable and care should be taken when routing cable. Note shielding procedure and make sure that the drain wires are connected as shown.

RS485 COMMUNICATIONS CONNECTION (CHANNEL LOOP)

Each BASYX IPR has one (1) channel for communications with additional BASYX controllers. There is no addressing required, and the IPR is a transparent device within the communication circuit. The standard limit of 256 controllers applies within the entire system, but is not dependent upon any specific configuration. Any number of controllers may be installed on the channel connection of the IPR repeater. **Figure 4** show the proper method for channel communications connection.

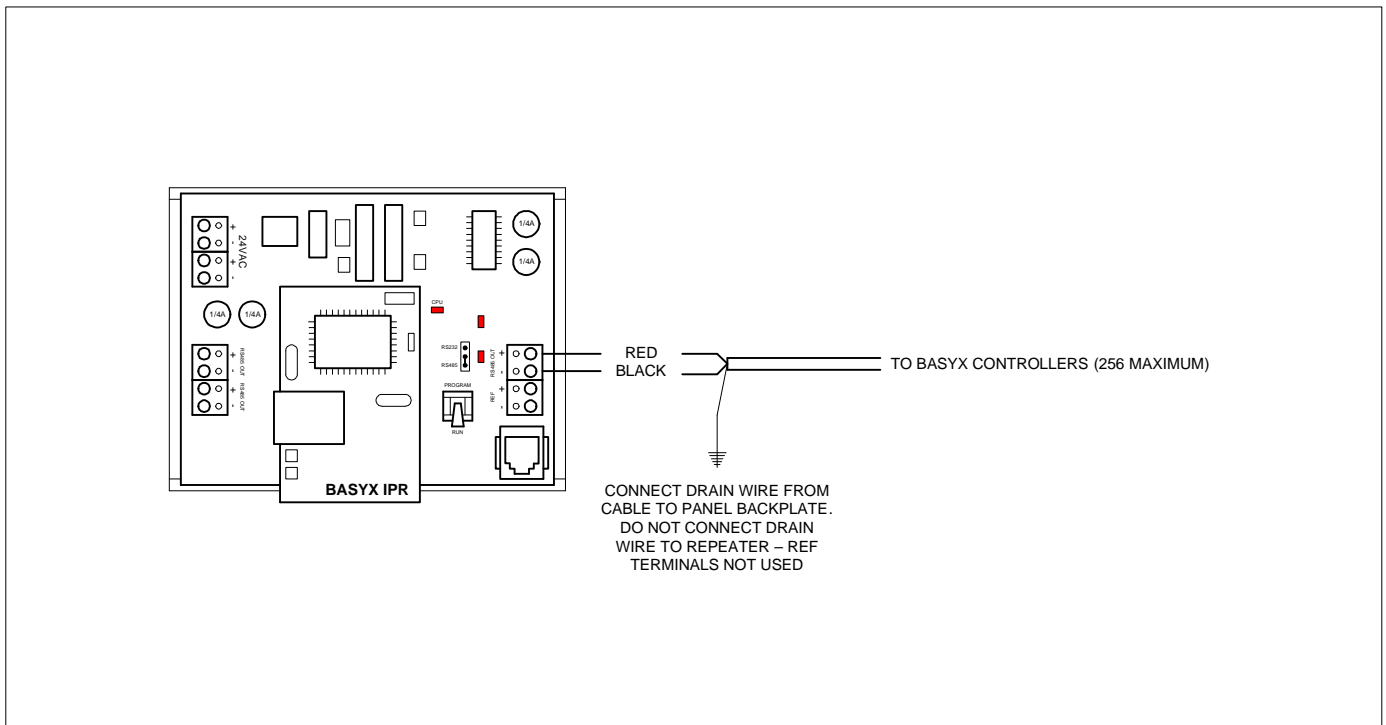

Figure 4: RS485 Channel Loop Communications Connection

NOTE: Do **NOT** connect shield drain wires to the IPR. Ground to backplate of panel or earth ground as shown.

Any number of controllers may be connected to the channel of any individual BASYX IPR repeater. The system capacity of 256 controllers must be observed for the total job configuration.

PROGRAM / RUN SWITCH OPERATION

The BASYX IPR is factory set, and no field use for the Program/Run switch is required. Insure that the switch is in the RUN position for proper operation.

The program mode is controlled by the program switch located adjacent to the RJ11 connector, and is in the PROGRAM mode when the switch is fully TOWARDS the RJ11 as indicated in **Figure 5**.

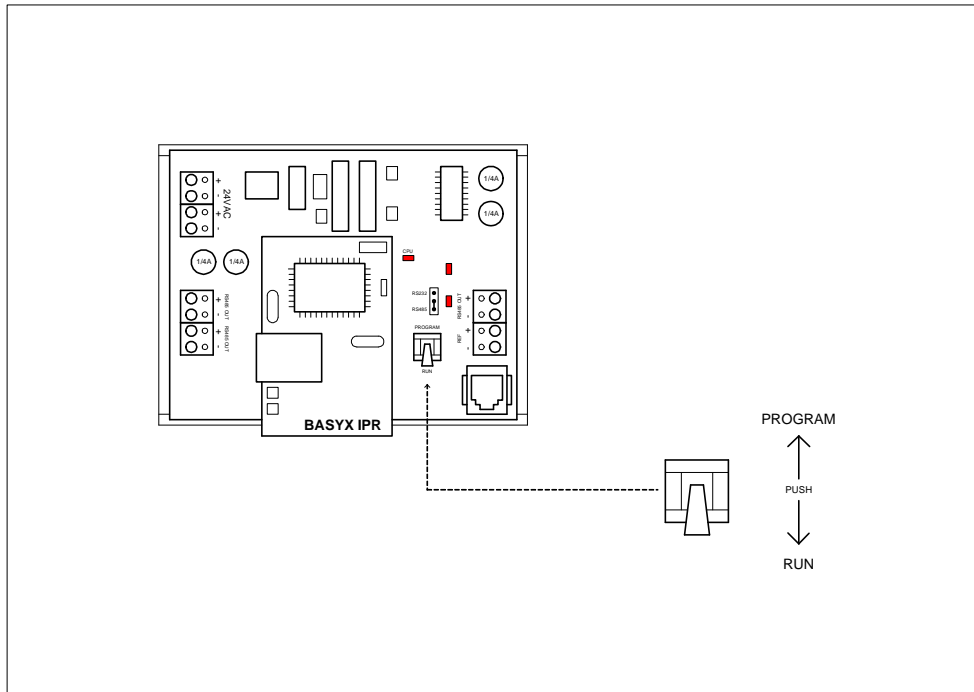

Figure 5: Program Switch Operation

IMPORTANT: Set program switch to run mode for proper operation. No field programming required for the BASYX IPR repeater module.

RS485 / RS232 JUMPER SETTINGS

The BASYX IPR must be setup to respond as a Communications Repeater. The board has a 3-Pin jumper to set the communications type required.

The jumper **MUST** be set to the RS485 setting for proper communications operation. The RS232 setting must **NOT** be used or system communications will not function.

Figure 6 shows the correct position of the jumper.

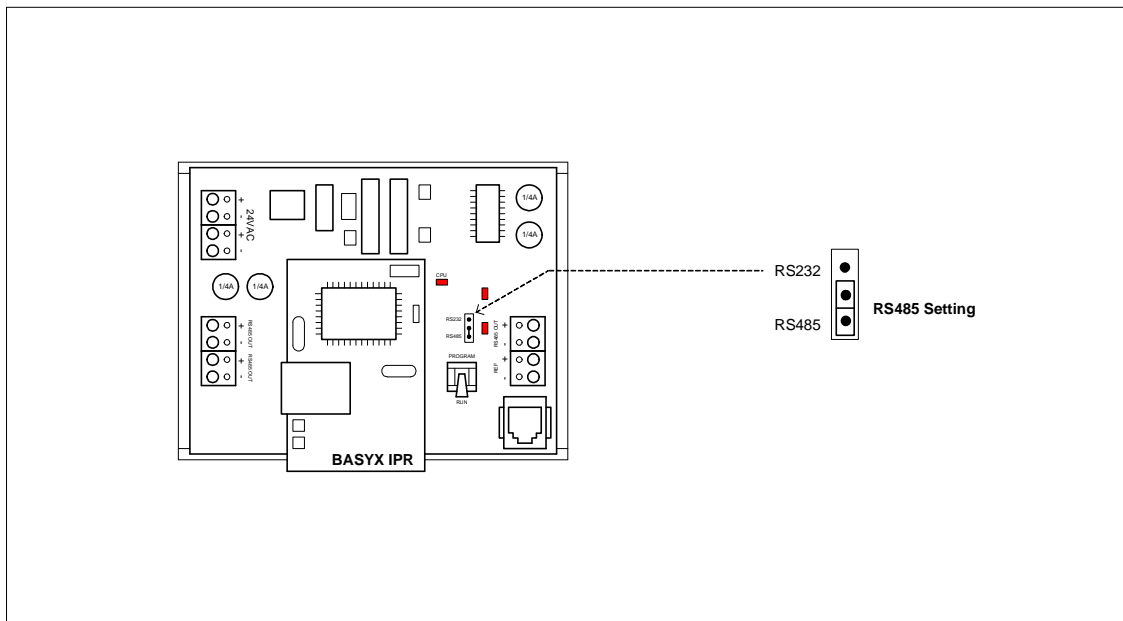

Figure 6: RS485/RS232 Jumper Settings

IMPORTANT: The jumper **MUST** be set to the RS485 position or communications will not function as required for system operation.

TYPICAL SYSTEM CONFIGURATION

The BASYX IPR may be installed in different methods to match system setup and operation.

1. To extend communications beyond the standard 4000' limitation.
2. To provide channels to match building layout and eliminate continuous system loop.
3. To add a branch of controllers within a standard communications loop.

Following are some typical examples of system configuration.

LOOP EXTENDER CONFIGURATION

Figure 7 shows a typical example when using the repeater to extend the communication loop length beyond the standard 4000' limitation.

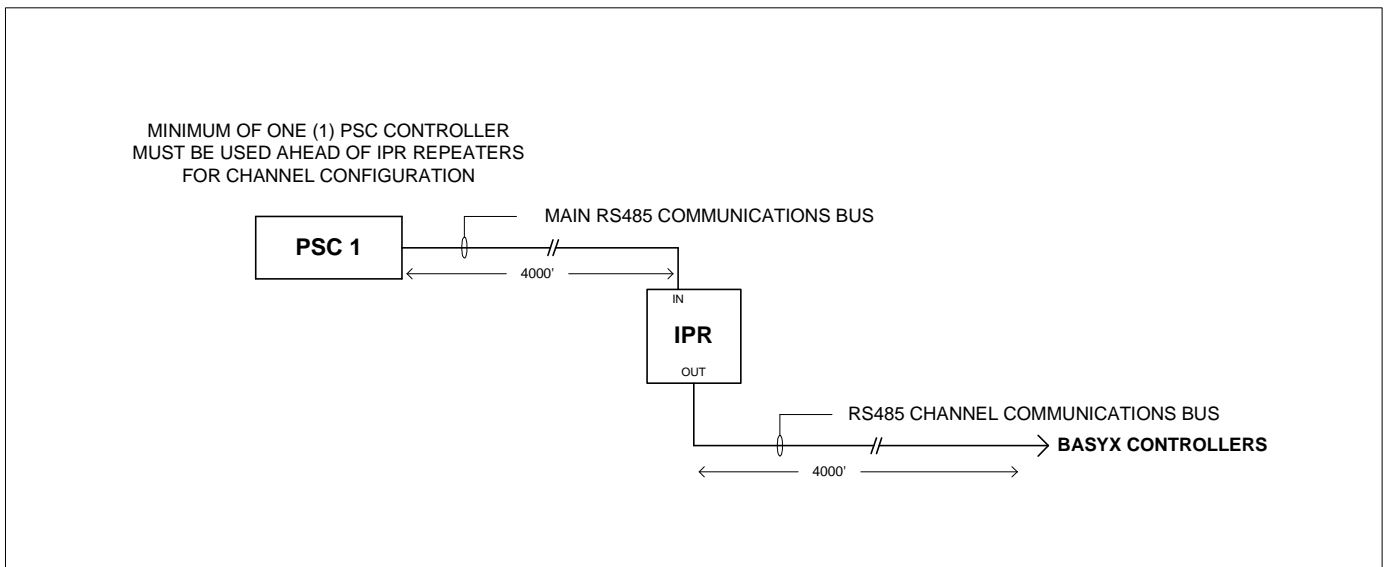

Figure 7: Typical Extender Mode Configuration

CHANNEL CONFIGURATION

The most common use for the BASYX IPR is to separate the building into zones or channels. This allows several daisy chain loops to originate from a single point.

Figure 8 shows a typical example when using the repeater to provide separate communication loops to match building layout.

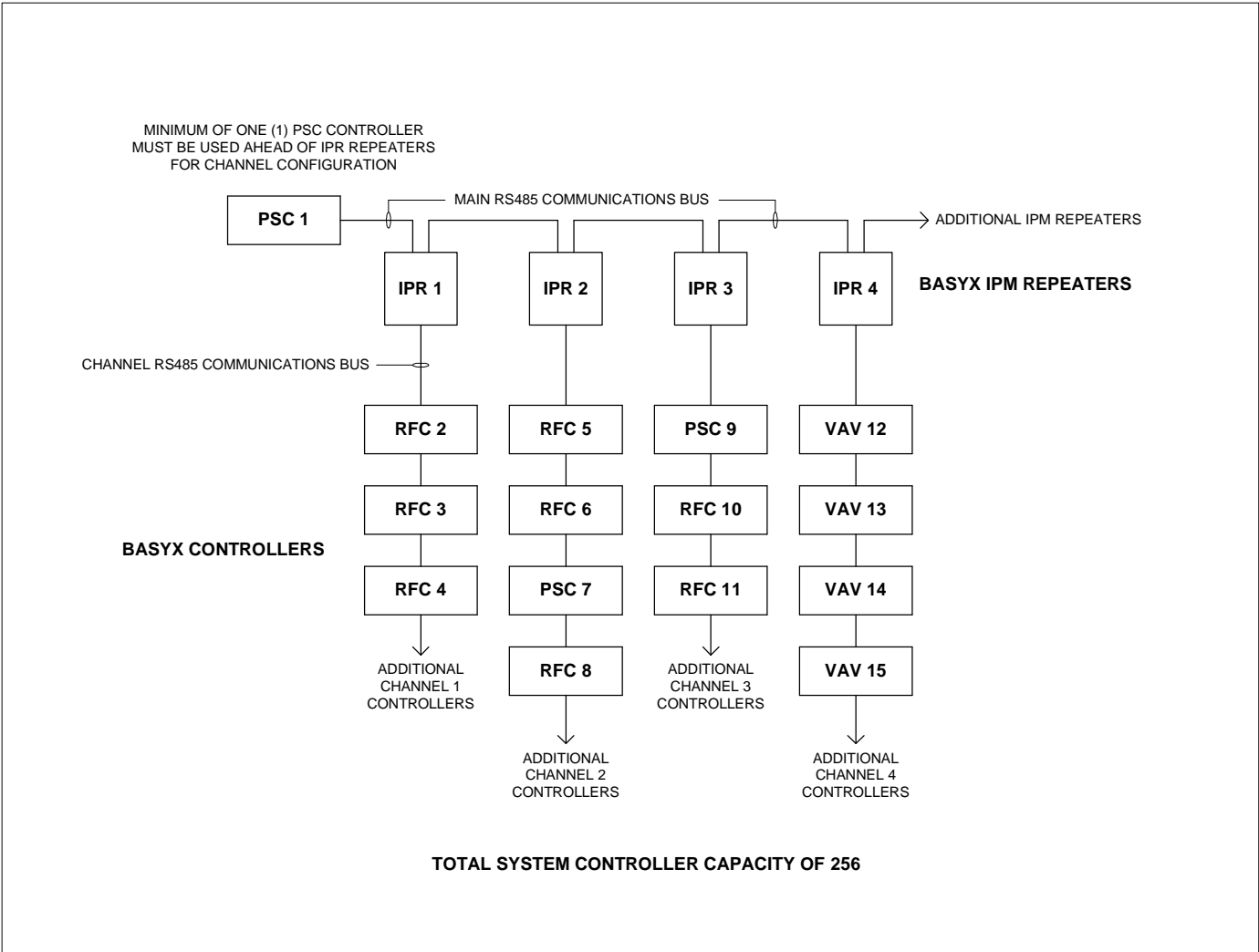

Figure 8: Typical Channel Mode Configuration

NOTE: Any number or style of BASYX controllers may be installed on the channel loops. The only limitation is that of the 256 total system controllers.

BRANCH CONFIGURATION

The IPR repeater may be used to install a branch within the system configuration. This is most common when adding to an existing system.

Figure 9 shows a typical example when using the repeater to provide a branch loop.

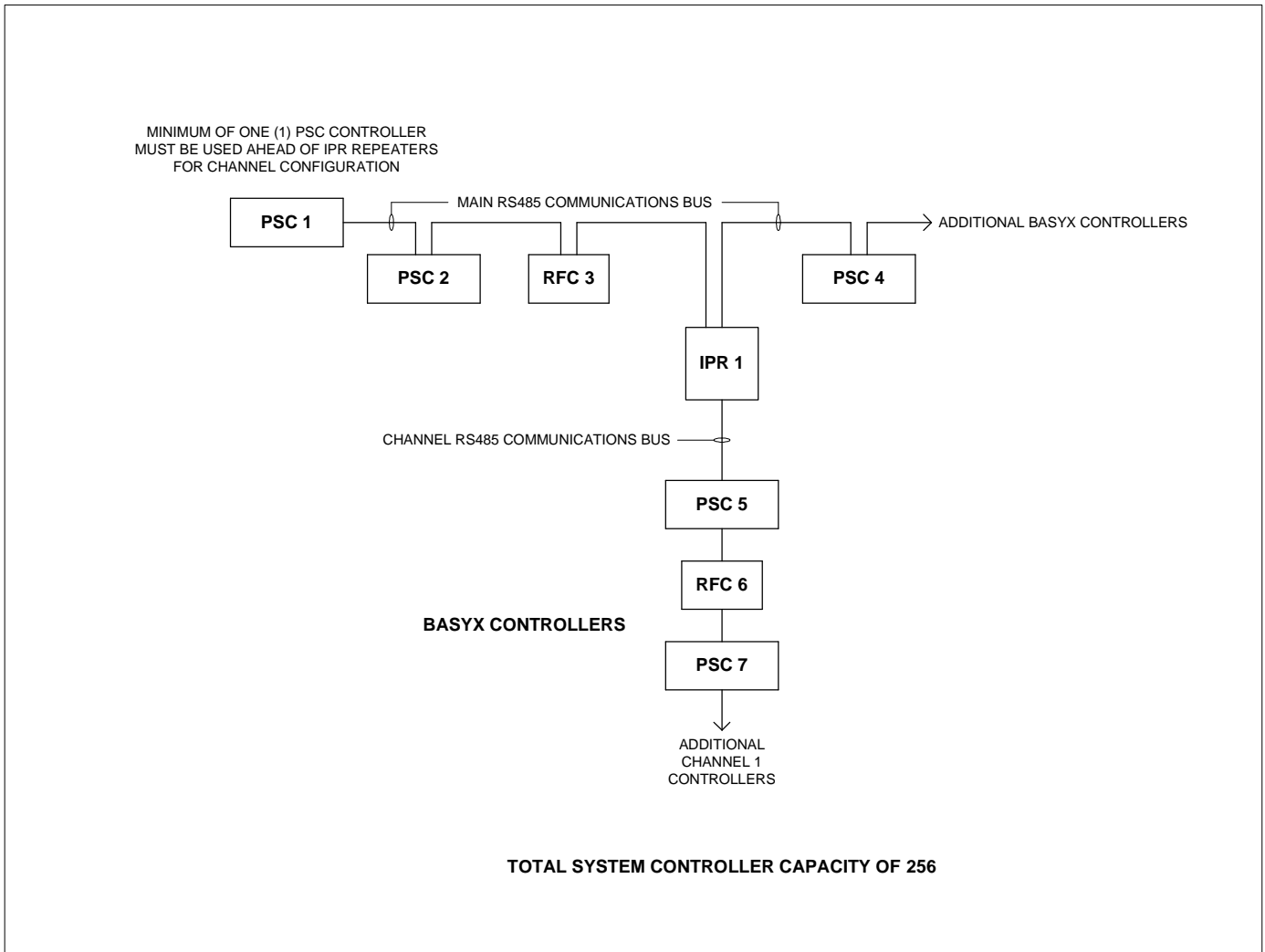

Figure 9: Typical Branch Mode Configuration

ABOUT THE BASYX PRODUCT LINE

The BASYX IPR is one product in a line of BASYX control products. The TriComm interface software package is a Windows based human interface used with the BASYX automation and control system. Tricomm will operate on any personal computer with the Windows 98,ME,2000, XP or Vista operating system.

The program provides a simple interface through direct connect, modem or internet to setup, operate and modify the operating parameters of the BASYX system, using easy to understand point-and-click commands. The drop-down system menus allow access to all system functions, and requires minimal computer experience for normal daily interaction with the system.

The BASYX system is designed specifically to meet today's building automation, facility and energy management needs. Triangle MicroSystems, Inc. develops and provides application support for control systems around the world. The company has a continuing commitment to research and development in order to provide new and improved products to the building automation market.

For more information contact:

Triangle MicroSystems, Inc.
Building Controls Division
2716 Discovery Drive
Raleigh, NC 27616-1852

Telephone: (919) 878-1880
Toll-Free: (800) 334-5548
Fax: (919) 872-2071

E-mail: sales@trianglemicrosystems.net
Website: www.trianglemicrosystems.net

The technical contents of this document, while accurate as of publication, are subject to change without notice.
No responsibility is assumed for its use.